



**TOWN OF PLACENTIA
VOLUNTEER FIRE DEPARTMENT**



**Invitation to Tender
Fire Department Training Centre
To Supply Materials and to
&
Install Town Owned Shipping Containers**

Invitation to Tender No.: ITT-072023-FD

Issued: May 27, 2026

Submission Deadline: June 17, 2026 2:00 PM

Table of Contents

PART 1 – INVITATION AND SUBMISSION INSTRUCTIONS4

1.1 Invitation to Bidders..... 4

1.3 Type of Contract for Deliverables 4

1.4 ITT Timetable 4

1.5 Submission of Bids..... 5

1.5.1 Bids to be Submitted at Prescribed Location 5

1.5.2 Bids to be Submitted on Time..... 5

1.5.3 Bids to be Submitted in Prescribed Format..... 5

To ensure consistency and quality in the information provided to bidders the Owner shall provide, by way of amendment to this tender in the form of an addendum, any relevant information with respect to the ITT inquiries received in writing without revealing the source of those inquiries. Bidders are cautioned that it is their responsibility to ensure that they receive all information relevant to this ITT. The Owner shall not be responsible for bidders who fail to inform themselves regarding the scope and nature of the work. The Owner shall publish all amendments to the Provincial MERX system and to the Town of Placentia web site: www.placentia.ca under Town Hall/Tenders. Bidders should check on a regular basis for ITT updates. Bidders are solely responsible for ensuring they are aware of and have complied with all amendments by tender closing time..... 5

1.5.5 Withdrawal of Bids..... 6

1.5.6 Bids Irrevocable after Submission Deadline..... 6

PART 2 – EVALUATION AND AWARD7

2.1 Stages of Evaluation 7

2.2 Stage I – Mandatory Submission Requirements..... 7

2.2.1 No Amendment to Forms..... 7

2.3 Stage II – Mandatory Technical Requirements 7

2.4 Stage III – Pricing 7

2.5 Selection of Lowest Compliant Bidder 7

2.6 Notice to Bidder and Execution of Agreement 7

2.7 Failure to Enter into Agreement..... 8

PART 3– TERMS AND CONDITIONS OF THE ITT PROCESS 9

3.1	General Information and Instructions.....	9
3.1.1	ITT Incorporated into Bid	9
3.1.2	Bidders to Follow Instructions	9
3.1.3	Bids in English	9
3.1.4	No Incorporation by Reference	9
3.1.5	References and Past Performance.....	9
3.1.6	Information in ITT Only an Estimate.....	9
3.1.7	Bidders to Bear Their Own Costs.....	9
3.1.8	Bid to be Retained by the Owner	10
3.1.9	Trade Agreements.....	10
3.1.10	No Guarantee of Volume of Work or Exclusivity of Contract	10
3.2.1	Bidders to Review ITT	10
3.2.2	All New Information to Bidders by Way of Addenda.....	10
3.2.3	Post-Deadline Addenda and Extension of Submission Deadline	10
3.2.4	Verify, Clarify and Supplement	11
3.3	Notification and Debriefing	11
3.3.1	Notification to Other Bidders	11
3.3.2	Debriefing	11
3.3.3	Supplier Complaint Process.....	11
3.4	Conflict of Interest and Prohibited Conduct	11
3.4.1	Conflict of Interest.....	11
	The Owner may disqualify a bidder for any conduct, situation or circumstances, determined by the Owner, in its sole and absolute discretion, to constitute a conflict of interest.	11
3.4.2	Disqualification for Prohibited Conduct	12
3.4.3	Bidder Not to Communicate with Media	12
3.4.4	No Lobbying	12
3.4.5	Illegal or Unethical Conduct.....	12

3.4.6	Past Performance or Past Conduct.....	12
3.5	Confidential Information.....	13
3.5.1	Confidential Information of the Owner.....	13
3.5.2	Confidential Information of Bidder.....	13
3.6	Reserved Rights and Limitation of Liability	14
3.6.1	Reserved Rights of the Owner.....	14
3.6.2	Limitation of Liability	14
3.7	Governing Law and Interpretation	15
APPENDIX A – FORM OF AGREEMENT		16
APPENDIX B – SUBMISSION FORM		17
APPENDIX C – PRICING FORM.....		19
Company Name.....		19
Bid Amount		19
HST 19		
Total Bid		19
bIDDER’S sIGNATURE _____.....		19
APPENDIX D – ITT PARTICULARS		20
A. THE DELIVERABLES		20
C. MANDATORY SUBMISSION REQUIREMENTS		21
1.	Submission Form (Appendix B)	21
2.	Pricing Form (Appendix C)	21
3.	Bid Security	21
4.	Other Mandatory Submission Requirements	21
D. MANDATORY TECHNICAL REQUIREMENTS		21
E. Construction Drawing Package		22

PART 1 – INVITATION AND SUBMISSION INSTRUCTIONS

1.1 Invitation to Bidders

This Invitation to Tender (the “ITT”) is an invitation by **The Town of Placentia** (herein after referred to as “the Owner”) to prospective bidders to submit bids for ITT-072023-FD, as further described in detail Section A of the ITT Particulars (Appendix D) (the “Deliverables”).

Background

The purpose of this project is to place, secure and upgrade four (4) sea cans supplied by the Town onto a **previously prepared concrete platform** to ultimately be used as a fire training centre. The sea cans are currently located on the training ground site located in Argentina.

Modifications will be fully detailed in Appendix D - the “Deliverables” and in Appendix E Construction Drawing Package.

This work will be performed by the successful bidder for the Placentia Volunteer Fire Department located approximately 120 kms west of St. John’s. Tender submissions will be reviewed by the Town’s CAO, Fire Chief and management of the Town of Placentia Public Works Department; final authorization to award will require a Motion of Council.

The successful candidate will preferably have shipping container conversion experience and be able to provide references from previous projects.

1.2 ITT Contact

For the purposes of this procurement process, the “ITT Contact” will be:

Ryan Snow
Manager of Engineering and Public Works - Rsnow@Placentia.ca

1.3 Type of Contract for Deliverables

The preferred supplier will be required to enter into an agreement with the Owner for the provision of the Deliverables in the form attached as Appendix A to the ITT (the “Agreement”). It is the Owner’s intention to enter into an Agreement with the preferred supplier(s).

1.4 ITT Timetable

Issue Date of ITT	May 17, 2026
Site Visit / Pre-Bid Meeting [remove if no site visit or pre-bid meeting]	June 3, 2026. Camryn Road , Pouch Cove @ 2:00PM Fire Training Grounds
Deadline for Questions	June 12, 2026
Deadline for Issuing Addenda	June 15, 2026
Submission Deadline	June 17, 2023 2:00 PM local time
Public opening	June 18, 2023 2:15 PM local time
Anticipated Execution Date for Agreement	TBD

The ITT timetable is tentative only and may be changed by the Owner at any time.

Public Opening will take place at the Town of Placentia Boardroom, 25 Patterson Drive, Placentia, NL.

1.5 Submission of Bids

The following section deals with the required method of submission; as this is a sealed tender bid, documents delivered electronically will not be accepted.

1.5.1 Bids to be Submitted at Prescribed Location

Bids must be clearly marked with the Tender # and submitted at:

Town of Placentia
P.O. Box 99
17 Patterson Drive
Placentia, NL A0B 2Y0

1.5.2 Bids to be Submitted on Time

Bids must be submitted at the location set out above on or before the Submission Deadline. Bids submitted after the Submission Deadline will be rejected. Onus and responsibility rest solely with the bidder to deliver its bid to the exact location indicated in the ITT on or before the Submission Deadline. The Owner does not accept any responsibility for submissions delivered to any other location by the bidder or its delivery agents. Bidders are advised to make submissions well before the deadline. Bidders making submissions near the deadline do so at their own risk.

1.5.3 Bids to be Submitted in Prescribed Format

Bidders must submit one (1) hard copy and a USB drive containing one (1) electronic copy of their proposal in PDF format enclosed in the sealed tender package. If there is a conflict or inconsistency between the hard copy and the electronic copy of the bid, the hard copy of the bid will prevail. Bids should be prominently marked with the ITT title and number (see ITT cover page), with the full legal name and return address of the bidder.

1.5.4 Amendment of Bids

Bidders may amend their bids after they have been submitted if, and only if, the amendment is delivered prior to the Submission Deadline marked with this ITT title and number and the full legal name and return address of the bidder to the location set out above. Any amendment should clearly indicate which part of the bid the amendment is intended to affect. Amendments must be submitted at the location set out above on or before the Submission Deadline. Amendments submitted after the Submission Deadline will not be accepted.

Written inquiries and requests for clarification shall be accepted up to 5 working days prior to the closing time. Inquiries and requests for clarification received after this date shall not be addressed. Verbal responses shall not be binding on either party.

To ensure consistency and quality in the information provided to bidders the Owner shall provide, by way of amendment to this tender in the form of an addendum, any relevant information with respect to the ITT inquiries received in writing without revealing the source of those inquiries. Bidders are cautioned that it is their responsibility to ensure that they receive all information

relevant to this ITT. The Owner shall not be responsible for bidders who fail to inform themselves regarding the scope and nature of the work. The Owner shall publish all amendments to the Provincial MERX system and to the Town of Placentia web site: www.placentia.ca under Town Hall/Tenders. Bidders should check on a regular basis for ITT updates. Bidders are solely responsible for ensuring they are aware of and have complied with all amendments by tender closing time.

1.5.5 Withdrawal of Bids

Bidders may withdraw their bids prior to the Submission Deadline. To withdraw a bid, a notice of withdrawal must be sent to the ITT Contact prior to the Submission Deadline and must be signed by an authorized representative of the bidder. The Owner is under no obligation to return withdrawn bids.

1.5.6 Bids Irrevocable after Submission Deadline

Bids shall be irrevocable for a period of twenty-one (21) days running from the moment that the Submission Deadline passes.

[End of Part 1]

IMPORTANT

There is an identical unit currently assembled and being used by the Town of Pouch Cove. There will be a site meeting June 3rd @ 2:00PM at the fire training grounds off Camron Road, Pouch Cove. The Fire Chief, Derek Sullivan will be there for site access and viewing.

Access to the construction site and owner suppliers materials in Argentia can be made available by calling:

Rodney Cooney - Public Works Superintendent @ 709-227-1534

PART 2 – EVALUATION AND AWARD

2.1 Stages of Evaluation

The Owner will conduct the evaluation of bids in the following stages:

2.2 Stage I – Mandatory Submission Requirements

Stage I will consist of a review to determine which bids comply with all of the mandatory submission requirements. Bids that do not comply with all of the mandatory submission requirements as of the Submission Deadline will, subject to the express and implied rights of the Owner, be disqualified and not evaluated further. The mandatory submission requirements are listed in Section C of the ITT Particulars (Appendix D).

2.2.1 No Amendment to Forms

Other than inserting the information requested on the mandatory submission forms set out in the ITT, a bidder may not make any changes to any of the forms. Any bid containing any such changes, whether on the face of the form or elsewhere in the bid, may be disqualified.

2.3 Stage II – Mandatory Technical Requirements

Stage II will consist of a review to determine which bids comply with all of the mandatory technical requirements. Bids that do not comply with all of the mandatory technical requirements as of the Submission Deadline will, subject to the express and implied rights of the Owner, be disqualified and not evaluated further. The mandatory technical requirements are listed in Section D of the ITT Particulars (Appendix D).

2.4 Stage III – Pricing

Stage III will consist of a scoring of the submitted pricing of each compliant bid in accordance with the evaluation method set out in the Pricing Form (Appendix C). The evaluation of price will be undertaken after the evaluation of mandatory requirements has been completed.

2.5 Selection of Lowest Compliant Bidder

Subject to the Owner's reserved rights, the proven qualified bidder with the lowest pricing will be selected to enter into the Agreement in accordance with the following section. In the event of a tie, the selected bidder will be determined by way of a coin toss.

2.6 Notice to Bidder and Execution of Agreement

Notice of selection by the Owner to the preferred supplier shall be in writing. The preferred supplier shall execute the Agreement in the form attached as Appendix A to this ITT and satisfy any other applicable conditions of this ITT, within seven (7) days of notice of selection. This provision is solely for the benefit of the Owner and may be waived by the Owner.

2.7 Failure to Enter into Agreement

If a selected bidder fails to execute the Agreement or satisfy the pre-conditions of award listed in Section E of ITT Particulars (Appendix D) within seven (7) days of notice of selection the Owner may, without incurring any liability, proceed with the selection of another bidder and pursue all remedies available to the Owner.

[End of Part 2]

PART 3 – TERMS AND CONDITIONS OF THE ITT PROCESS

3.1 General Information and Instructions

3.1.1 ITT Incorporated into Bid

All of the provisions of this ITT are deemed to be accepted by each bidder and incorporated into each bidder's bid. A bidder who submits conditions, options, variations or contingent statements to the terms as set out in this ITT, including the terms of the Agreement in Appendix A, either as part of its bid or after receiving notice of selection, unless otherwise indicated, may be disqualified. If a bidder is not disqualified despite such changes or qualifications, the provisions of this ITT, including the Agreement set out in Appendix A, will prevail over any such changes or qualifications in the bid.

3.1.2 Bidders to Follow Instructions

Bidders should structure their bids in accordance with the instructions in this ITT. Where information is requested in this ITT, any response made in a bid should reference the applicable section numbers of this ITT.

3.1.3 Bids in English

All bids are to be in English only.

3.1.4 No Incorporation by Reference

The entire content of the bidder's bid should be submitted in a fixed form, and the content of websites or other external documents referred to in the bidder's bid but not attached will **not** be considered to form part of its bid.

3.1.5 References and Past Performance

In the evaluation process, the Owner may include information provided by the bidder's references and may also consider the bidder's past performance or conduct on previous contracts with the Owner or other institutions.

3.1.6 Information in ITT Only an Estimate

The Owner and its advisers make no representation, warranty or guarantee as to the accuracy of the information contained in this ITT or issued by way of addenda. Any quantities shown or data contained in this ITT or provided by way of addenda are estimates only and are for the sole purpose of indicating to bidders the general scale and scope of the Deliverables. It is the bidder's responsibility to obtain all the information necessary to prepare a bid in response to this ITT.

3.1.7 Bidders to Bear Their Own Costs

The bidder will bear all costs associated with or incurred in the preparation and presentation of its bid, including, if applicable, costs incurred for interviews or demonstrations.

3.1.8 Bid to be Retained by the Owner

The Owner will not return the bid or any accompanying documentation submitted by a bidder.

3.1.9 Trade Agreements

Bidders should note that procurements falling within the scope of the Canadian Free Trade Agreement, the Atlantic Procurement Agreement, and/or the Canada-European Union Comprehensive Economic Trade Agreement are subject to those trade agreements but that the rights and obligations of the parties will be governed by the specific terms of this ITT.

3.1.10 No Guarantee of Volume of Work or Exclusivity of Contract

Bidders Note: This section is for use for a standing offer ITT only. There are no instructions provided herein on the guarantee of volume of work or exclusivity of contract.

3.2 Communication after Issuance of ITT

3.2.1 Bidders to Review ITT

Bidders shall promptly examine all of the documents comprising this ITT, and

- (a) shall report any errors, omissions or ambiguities; and
- (b) may direct questions or seek additional information

in writing by email to the ITT Contact on or before the Deadline for Questions. All questions or comments submitted by bidders by email to the ITT Contact shall be deemed to be received once the email has entered into the ITT Contact's email inbox. No such communications are to be directed to anyone other than the ITT Contact, and the Owner shall not be responsible for any information provided by or obtained from any source other than the ITT Contact. The Owner is under no obligation to provide additional information. It is the responsibility of the bidder to seek clarification from the ITT Contact on any matter it considers to be unclear. The Owner shall not be responsible for any misunderstanding on the part of the bidder concerning this ITT or its process.

3.2.2 All New Information to Bidders by Way of Addenda

This ITT may be amended only by addendum in accordance with this section. If the Owner, for any reason, determines that it is necessary to provide additional information relating to this ITT, such information will be communicated to all bidders by addenda. Each addendum forms an integral part of this ITT and may contain important information, including significant changes to this ITT. Bidders are responsible for obtaining all addenda issued by the Owner. In the Submission Form (Appendix B), bidders should confirm their receipt of all addenda by setting out the number of each addendum in the space provided.

3.2.3 Post-Deadline Addenda and Extension of Submission Deadline

If the Owner determines that it is necessary to issue an addendum after the Deadline for Issuing Addenda, the Owner may extend the Submission Deadline for a reasonable period of time.

3.2.4 Verify, Clarify and Supplement

When evaluating bids, the Owner may request further information from the bidder or third parties in order to verify, clarify or supplement the information provided in the bidder's bid including but not limited to clarification with respect to whether a bid meets the mandatory technical requirements set out in Section D of the ITT Particulars (Appendix D). The Owner may revisit and re-evaluate the respondent's response or ranking on the basis of any such information.

Any responses received by the Owner from the bidder shall, if accepted by the Owner, form an integral part of the bidder's bid.

3.3 Notification and Debriefing

3.3.1 Notification to Other Bidders

In accordance with section 30 of the *Public Procurement Regulations*, once the Agreement is awarded by the Owner, the outcome of the ITT will be publicly posted on the Provincial MERX site and at www.placentia.ca.

3.3.2 Debriefing

Unsuccessful bidders may request a debriefing within ten (10) business days after the award has been posted. The request must be sent in writing to the ITT Contact. The intent of the debriefing information session is to aid the bidder in presenting a better bid in subsequent procurement opportunities. The debriefing process is not for the purpose of providing an opportunity to challenge the procurement process or its outcome.

3.3.3 Supplier Complaint Process

If a bidder wishes to register a complaint with respect to the ITT process, it should provide it in writing and within the parameters established by section 25 of the *Public Procurement Regulations*, as amended. The notice must provide a detailed explanation of the bidder's concerns with the procurement process or its outcome, in addition to such other information as may be required by the *Regulations*. Bidders should note that these complaint procedures are separate and distinct from any dispute resolution processes that may be provided for under applicable trade agreements. If a bidder wishes to dispute a matter under an applicable trade agreement, the bidder must follow the process set out in the trade agreement.

3.4 Conflict of Interest and Prohibited Conduct

3.4.1 Conflict of Interest

The Owner may disqualify a bidder for any conduct, situation or circumstances, determined by the Owner, in its sole and absolute discretion, to constitute a conflict of interest.

The Owner reserves the right to disqualify any bidder that in the Owner's sole opinion has an actual or potential conflict of interest or an unfair advantage or may permit the bidder to continue and impose such terms and conditions, as the Owner in its sole discretion may require.

For the purposes of this ITT, the term "Conflict of Interest" includes, but is not limited to, any situation or circumstance where in relation to the ITT process, the bidder has an unfair advantage or engages in conduct, directly or indirectly, that may give it an unfair advantage, including but

not limited to: (i) having, or having access to, confidential information of the Owner in the preparation of its bid that is not available to other bidders, (ii) communicating with any person with a view to influencing preferred treatment in the ITT process (including but not limited to the lobbying of decision makers involved in the ITT process), or (iii) engaging in conduct that compromises, or could be seen to compromise, the integrity of the open and competitive ITT process or render that process non-competitive or unfair.

Bidders are required to disclose, to the ITT Contact, any potential or perceived conflict of interest issues prior to ITT closing date and time.

3.4.2 Disqualification for Prohibited Conduct

The Owner may disqualify a bidder, rescind a notification of selection or terminate a contract subsequently entered into if the Owner determines that the bidder has engaged in any conduct prohibited by this ITT.

3.4.3 Bidder Not to Communicate with Media

Bidders must not at any time directly or indirectly communicate with the media in relation to this ITT or any agreement entered into pursuant to this ITT without first obtaining the written permission of the ITT Contact.

3.4.4 No Lobbying

Bidders must not, in relation to this ITT or the evaluation and selection process, engage directly or indirectly in any form of political or other lobbying whatsoever to influence the selection of the successful bidder(s).

3.4.5 Illegal or Unethical Conduct

Bidders must not engage in any illegal business practices, including activities such as bid-rigging, price-fixing, bribery, fraud, coercion or collusion. Bidders must not engage in any unethical conduct, including lobbying, as described above, or other inappropriate communications; offering gifts to any employees, officers, agents, elected or appointed officials or other representatives of the Owner; deceitfulness; submitting bids containing misrepresentations or other misleading or inaccurate information; or any other conduct that compromises or may be seen to compromise the competitive process provided for in this ITT.

3.4.6 Past Performance or Past Conduct

The Owner may prohibit a supplier from participating in a procurement process based on past performance or based on inappropriate conduct in a prior procurement process, including but not limited to the following:

- (a) illegal or unethical conduct as described above;
- (b) The refusal of the supplier to honour submitted pricing or other commitments; or
- (c) any conduct, situation or circumstance determined by the Owner, in its sole and absolute discretion, to have constituted a Conflict of Interest.

In addition, the Owner may suspend the bidding privileges of a supplier in regard to non-compliant or substandard performance in accordance with section 26 of the *Public Procurement Regulations*.

3.5 Confidential Information

3.5.1 Confidential Information of the Owner

All information provided by or obtained from the Owner in any form in connection with this ITT either before or after the issuance of this ITT:

- (a) is the sole property of the Owner and must be treated as confidential;
- (b) is not to be used for any purpose other than replying to this ITT and the performance of the Agreement;
- (c) must not be disclosed without prior written authorization from the Owner; and
- (d) must be returned by the bidder to the Owner immediately upon the request of the Owner.

3.5.2 Confidential Information of Bidder

This procurement process is subject to the *Access to Information and Protection of Privacy Act, 2015 (ATIPPA, 2015)*. A bidder must identify any information in its bid or any accompanying documentation supplied in confidence for which confidentiality is requested to be maintained by the Owner. The confidentiality of such information will be maintained by the Owner, except as otherwise required by law or by order of a court or tribunal. Bidders are advised that their bids will, as necessary, be disclosed, on a confidential basis, to advisers retained by the Owner to advise or assist with the ITT process, including the evaluation of bids.

The proponent agrees that any specific information in its submission that may qualify for an exemption from disclosure under subsection 39(1) of the *ATIPPA, 2015* has been identified in its submission. If no specific information has been identified it is assumed that, in the opinion of the proponent, there is no specific information that qualifies for an exemption under the subsection 39(1) of the *ATIPPA, 2015*.

Contracting with the Owner is a public process. Information provided through this process will be disclosed when requested under the *ATIPPA, 2015*, except where disclosure of that information is harmful to the business' interests, as set out in the three-part test in the *ATIPPA, 2015*.

Information, including the financial value of a contract resulting from this procurement process, will be publicly released as part of the award notification process, in accordance with section 30 of the *Public Procurement Regulations*.

If a bidder has any questions about the collection and use of personal information pursuant to this ITT, questions are to be submitted to the ITT Contact. Further information relating to subsection 39(1) of the *ATIPPA, 2015* is provided in guidance documents available through the Office of the Information and Privacy Commissioner at <https://oipc.nl.ca/guidance/documents>.

3.6 Reserved Rights and Limitation of Liability

3.6.1 Reserved Rights of the Owner

The Owner reserves the right to:

- (a) make public the names of any or all bidders as well as each bid price and value of contract;
- (b) make changes, including substantial changes, to this ITT provided that those changes are issued by way of addendum in the manner set out in this ITT;
- (c) request written clarification or the submission of supplementary written information in relation to the clarification request from any bidder and incorporate a bidder's response to that request for clarification into the bidder's bid. This shall not be an opportunity for bid repair;
- (d) assess a bidder's bid on the basis of: (i) a financial analysis determining the actual cost of the bid when considering factors including quality, service, price and transition costs arising from the replacement of existing goods, services, practices, methodologies and infrastructure (howsoever originally established); and (ii) in addition to any other evaluation criteria or considerations set out in this ITT, consider any other relevant information that arises during this ITT process;
- (e) waive formalities and accept bids that substantially comply with the requirements of this ITT;
- (f) verify with any bidder or with a third party any information set out in a bid;
- (g) check references other than those provided by any bidder;
- (h) disqualify a bidder, rescind a notice of selection or terminate a contract subsequently entered into if the bidder has engaged in any conduct that breaches the process rules or otherwise compromises or may be seen to compromise the competitive process;
- (i) cancel this ITT process at any stage;
- (j) cancel this ITT process at any stage and issue a new ITT for the same or similar deliverables;
- (k) accept any bid in whole or in part; or
- (l) reject any or all bids;

and these reserved rights are in addition to any other express rights or any other rights that may be implied in the circumstances.

3.6.2 Limitation of Liability

By submitting a bid, each bidder agrees that:

- (a) neither the Owner nor any of its employees, officers, agents, elected or appointed officials, advisors or representatives will be liable, under any circumstances, for any claim arising

out of this ITT process including but not limited to costs of preparation of the bid, loss of profits, loss of opportunity or for any other claim; and

- (b) the bidder waives any right to or claim for any compensation of any kind whatsoever, including claims for costs of preparation of the bid, loss of profit or loss of opportunity by reason of the Owner's decision not to accept the bid submitted by the bidder, to enter into an agreement with any other bidder or to cancel this bidding process, and the bidder shall be deemed to have agreed to waive such right or claim.

3.7 Governing Law and Interpretation

These Terms and Conditions of the ITT Process (Part 3):

- (a) are intended to be interpreted broadly and independently (with no particular provision intended to limit the scope of any other provision);
- (b) are non-exhaustive and shall not be construed as intending to limit the pre-existing rights of the Owner; and
- (c) are to be governed by and construed in accordance with the laws of the Province of Newfoundland & Labrador and the federal laws of Canada applicable therein.

[End of Part 3]

APPENDIX A – FORM OF AGREEMENT

The validity review has been completed relevant to ITT-072023-FD **Invitation to Tender for Supply of Materials and to Install Town Owned Shipping Containers** for the Fire Training Centre in Argentia.

WITNESSETH that in consideration of the agreements and conditions herein contained, the parties hereto agree to the terms and conditions of the Invitation to Tender package including any and all addendums and the quotation submitted by the Bidder.

All securities and pertinent documentation required within this document must be renewed prior to the commencement of the contract period.

IN WITNESS WHEREOF the parties hereto have unto their hands and seals subscribed and set the day and year first before written

Town of Placentia

The Corporate Seal of the Town of Placentia

Was hereunto affixed at Placentia in the

Jamie Neville, Mayor

Province of Newfoundland and Labrador

On the ____ day of _____, 2026.

Witness

The Contractor

The Corporate Seal of the Contractor

Was hereunto affixed at _____ in the

Company Name

Province of Newfoundland and Labrador

On the ____ day of _____, 2026.

Company Signatory

Witness

APPENDIX B – SUBMISSION FORM

1. Bidder Information

Please fill out the following form, naming one person to be the bidder's contact for the ITT process and for any clarifications or communication that might be necessary.	
Full Legal Name of Bidder:	
Any Other Relevant Name under which Bidder Carries on Business:	
Street Address:	
City, Province/State:	
Postal Code:	
Phone Number:	
Fax Number:	
Company Website (if any):	
Bidder Contact Name and Title:	
Bidder Contact Phone:	
Bidder Contact Fax:	
Bidder Contact Email:	

2. Offer

The bidder has carefully examined the ITT documents and has a clear and comprehensive knowledge of the Deliverables required under the ITT. By submitting a bid, the bidder agrees and consents to the terms, conditions and provisions of the ITT, including the Form of Agreement, and offers to provide the Deliverables in accordance therewith at the rates set out in the completed Pricing Form (Appendix C).

3. Rates

The bidder has submitted its rates in accordance with the instructions in the ITT and in the Pricing Form (Appendix C). The bidder confirms that it has factored all of the provisions of Appendix A, including insurance and indemnity requirements, into its pricing assumptions and calculations.

4. Addenda

The bidder is deemed to have read and accepted all addenda issued by the Owner. The onus is on bidders to make any necessary amendments to their bids based on the addenda. The bidder is requested to confirm that it has received all addenda by listing the addenda numbers, or if no addenda were issued by writing the word "None", on the following line:
 _____ . Bidders who fail to complete this section will be deemed to have received all posted addenda.

5. No Prohibited Conduct

The bidder declares that it has not engaged in any conduct prohibited by this ITT.

6. Disclosure of Information

The bidder hereby agrees that any information provided in this bid, even if it is identified as being supplied in confidence, may be disclosed where required by law or by order of a court or tribunal. The bidder hereby consents to the disclosure, on a confidential basis, of this bid by the Owner to the advisers retained by the Owner to advise or assist with the ITT process, including with respect to the evaluation of this bid.

7. Bid Irrevocable

The bidder agrees that its tender shall be irrevocable for a period of twenty-one (21) days following the Submission Deadline.

8. Execution of Agreement

The bidder agrees that in the event its bid is selected by the Owner, in whole or in part, it will finalize and execute the Agreement in the form set out in Appendix A to this ITT in accordance with the terms of this ITT.

Signature of Witness

Signature of Bidder Representative

Name of Witness

Name of Bidder Representative

Title of Bidder Representative

Date

I have the authority to bind the bidder.

APPENDIX C – PRICING FORM

1. Instructions on How to Complete Pricing Form

Rates must be provided in Canadian funds, inclusive of all applicable duties and taxes except for HST, which should be itemized separately.

Rates quoted by the bidder must be all-inclusive and must include all labour and material costs, all travel and carriage costs, all insurance costs, all costs of delivery to the Owner, all costs of installation and set-up, including any pre-delivery inspection charges, and all other overhead, including any fees or other charges required by law.

2. Evaluation of Pricing

The Town of Placentia does not bind itself to the lowest or any bidder. Consideration will be given to previous experience and references and timelines for start and completion as well as pricing. Bidders are asked to provide information on the foregoing along with their Pricing Form.

3. Pricing Form

COMPANY NAME	BID AMOUNT	HST	TOTAL BID

BIDDER'S SIGNATURE _____

NAME: Please Print: _____

APPENDIX D – ITT PARTICULARS

A. THE DELIVERABLES

Bidders are advised of the following:

- 1) *Appendix E provides a full set of Construction Drawings. Bidders are asked to note that references are made to the concrete slab in the drawing package; this slab has been completed so you are advised to disregard any instructions for preparation of same.*
- 2) *Bidders are advised for clarification purposes; it is to be understood that all references to install, construct, build, etc. means to supply materials and install, construct, build, etc. The successful bidder is responsible for sourcing and purchasing all materials, equipment, and tools required to perform the work as described herein.*

The Town of Placentia has three (3) 40' shipping containers and one (1) 20' shipping container that will be assembled to represent a three-story structure complete with ventilation simulation area and high angle rappelling area. The completed unit will be used by the Placentia Volunteer Fire Department as a fire training facility. The concrete pad and the shipping containers are being supplied by the Town of Placentia; however, the upgrades and additions are to be completed by the successful bidder with the qualifications to complete the work as prescribed in this tender document.

B. SCOPE OF WORK OVERVIEW

The following is the summary of work required; detailed specifications are provided in the construction drawings provided in Appendix E. **The bidder is required to supply and install all materials to complete the work outlined below and in the Construction Drawings.**

- Placement and securing of the containers on the existing concrete pad located in Argentina.
- Containers are to be positioned to represent a three-story structure complete with ventilation simulation area and high angle rappelling area.
- Modifications to the shipping containers include prep work/installation of the following:
 - ❖ Addition of reinforcement beams and posts
 - ❖ Cutting of openings for windows, doors, stairwell access points
 - ❖ Cutting of ventilation opening above the burn room.
 - ❖ Shutters installed to be opened and secured from inside the building
 - ❖ Door openings to be framed to accommodate steel man-doors
 - ❖ Safety railings as well as a metal walking deck will be installed
 - ❖ Other modifications as indicated in Appendix E
- The structure, when fully constructed, is to be rust proved and primed and then painted with a basic rust protection paint as follows:
 - ❖ The exterior will be painted #2061020 Champion Cobalt (available at the Paint Shop)
 - ❖ The doors and walking deck will be painted red
 - ❖ Interior rails will be painted yellow
 - ❖ Window shutters inside yellow

MATERIAL DISCLOSURES

N/A

C. MANDATORY SUBMISSION REQUIREMENTS

1. Submission Form (Appendix B)

Each bid must include a Submission Form (Appendix B) completed and signed by an authorized representative of the bidder.

2. Pricing Form (Appendix C)

Each bid must include a Pricing Form (Appendix C) completed according to the instructions contained in the form.

3. Bid Security

The Owner requires a \$10,000 bid security in the form of certified cheque or bank draft to be returned upon successful completion of the project.

4. Other Mandatory Submission Requirements

The successful bidder will provide:

- Proof of Good Standing with WorkplaceNL,
- Proof of General Liability Insurance for no less than \$2m per occurrence
- Comply with Municipal and Provincial regulations
- Adhere to National Building Code regulations where applicable
- COR Certification

D. MANDATORY TECHNICAL REQUIREMENTS

Work of this nature requires a professional company with a number of trained skills for conversion of the four containers into a fire training centre as per the drawings provided in Appendix E. These skills include but are not limited to lifting capabilities for the purpose of stacking the units; welding skills to create walkway and railings, carpentry to insert doors/windows, and any other such skills as identified by the bidder.

APPENDIX E

FIRE FIGHTING TRAINING FACILITY - CONSTRUCTION DRAWINGS

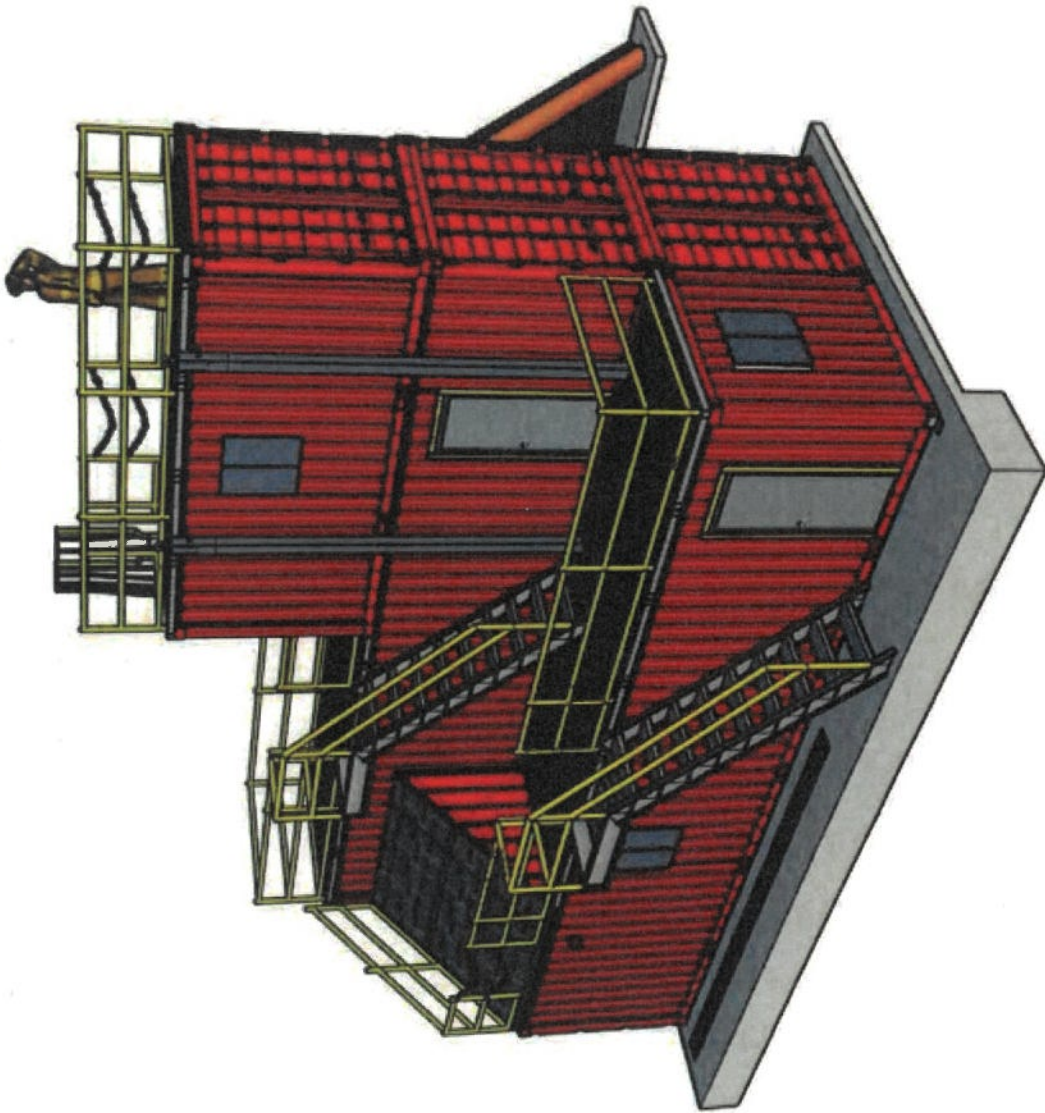

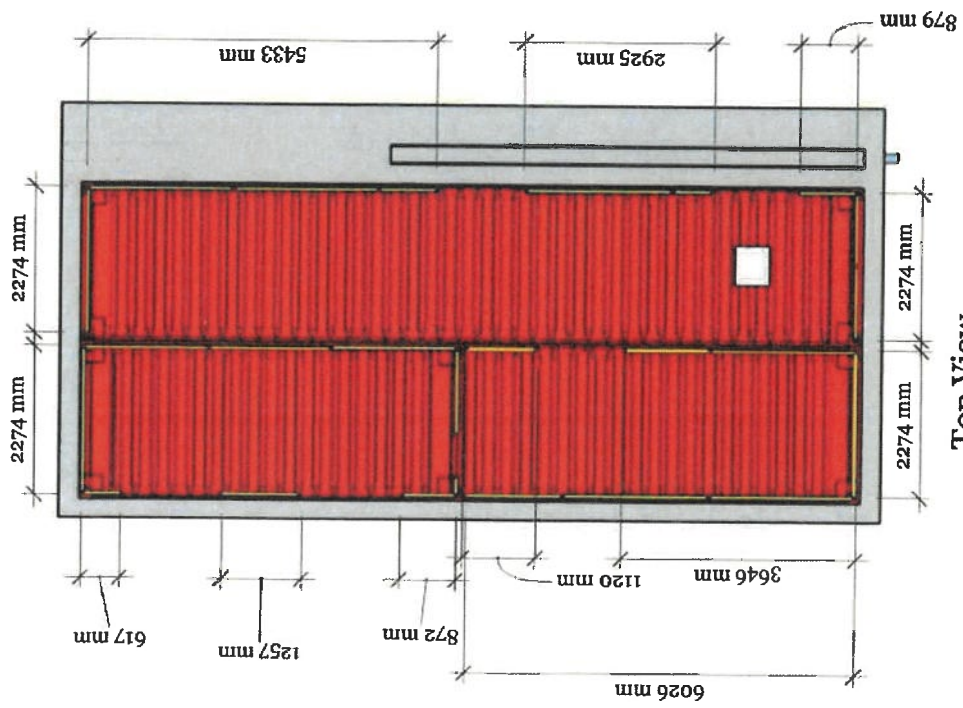
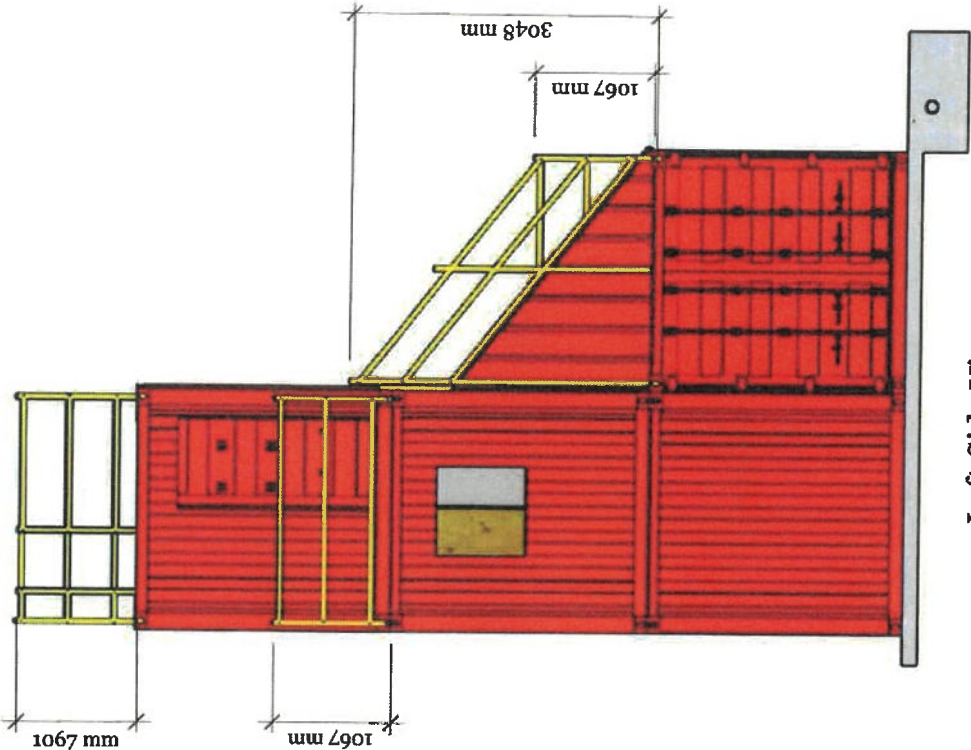

A 07

MM/DD/YY	REVISIONS	REMARKS
03/30/2021	1	
	2	
	3	
	4	
	5	

Firefighter Training Facility

Railing Dimensions

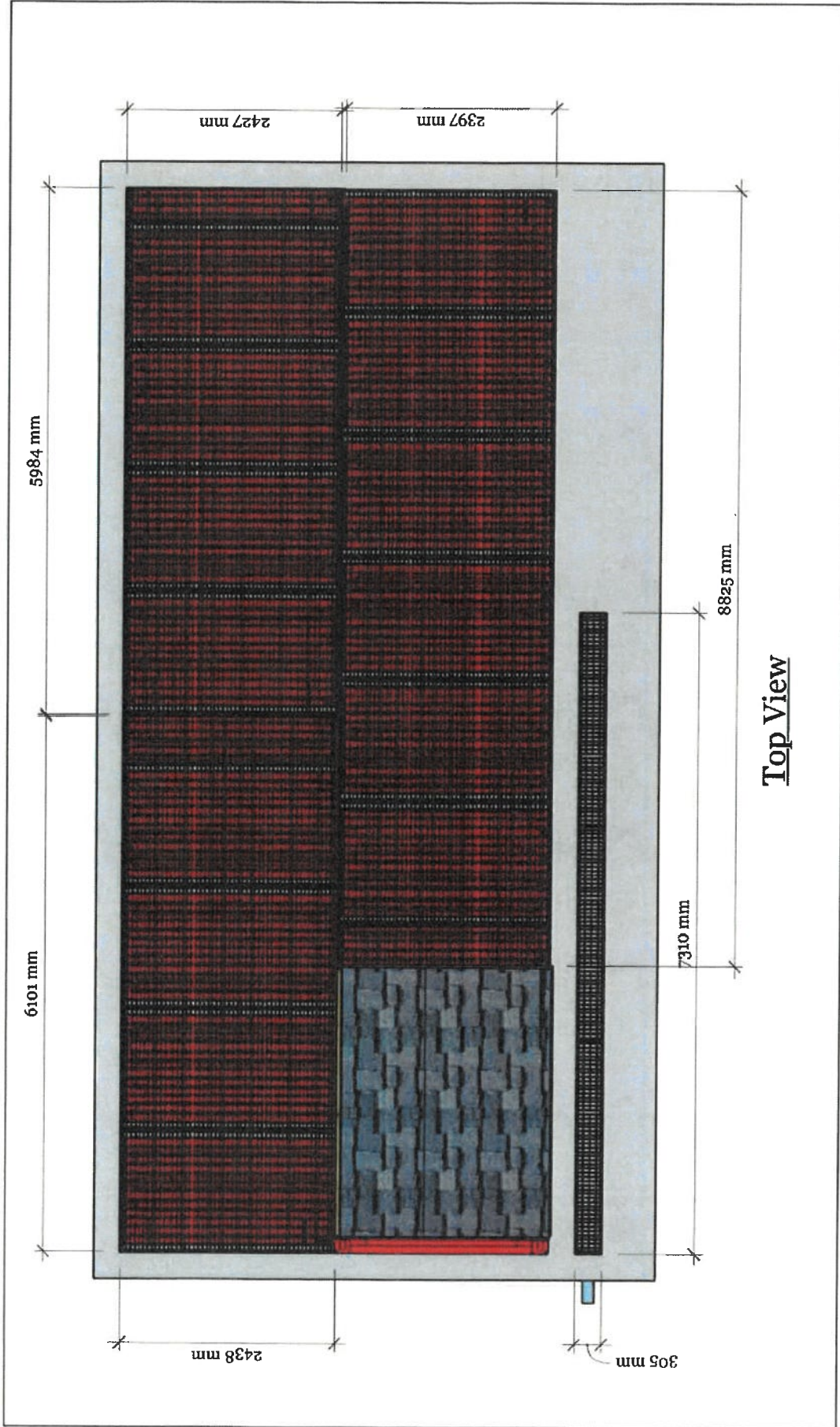

Top View

Grating

A 08

REVISIONS	
MM/DD/YY	REMARKS
1 03/30/2021	...
2	...
3	...
4	...
5	...

Firefighter Training Facility

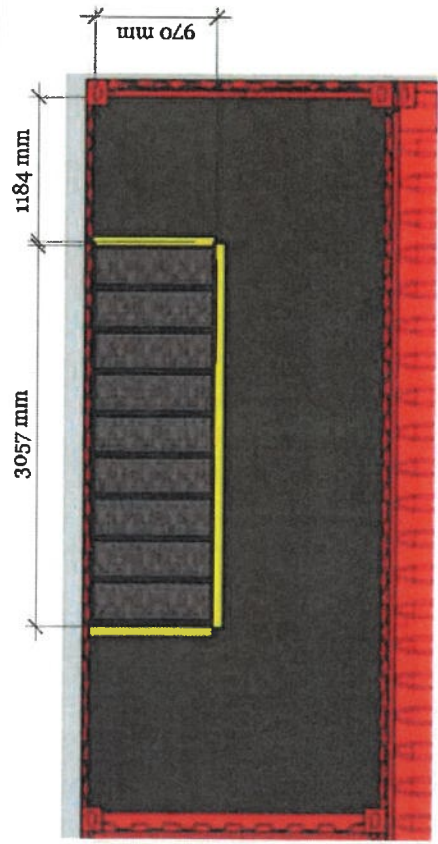

Top View

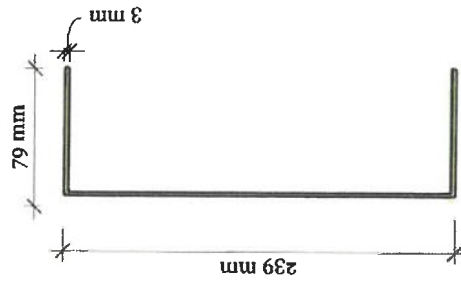

**Cutout cover - Sheet
Metal Cross-Section**

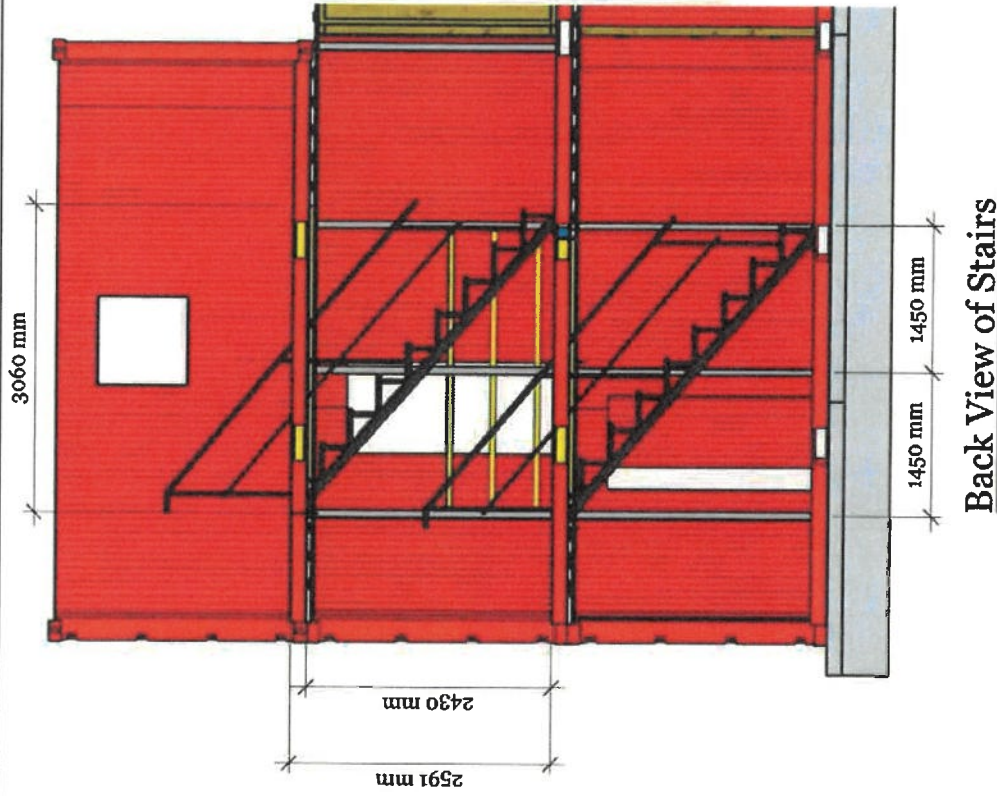

Back View of Stairs

A
09

REVISIONS	
MM/DD/YY	REMARKS
1	09/30/2021
2	
3	
4	
5	

Inside Stairs

Firefighter Training Facility

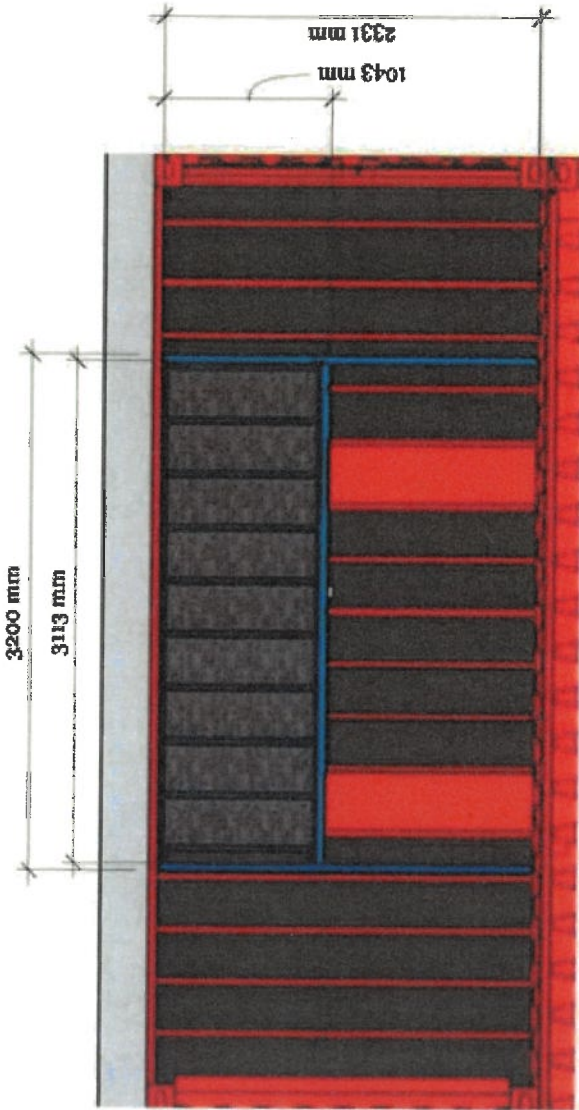

Top View

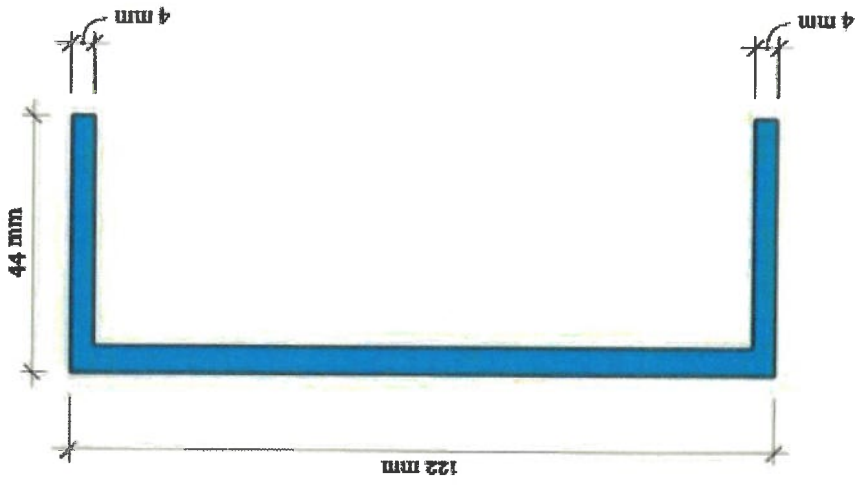

Floor Beam Cross-section

A 10

REVISIONS		REMARKS
1	MM/DD/YY 08/30/2021	
2		
3		
4		
5		

Inside Stair Floor Frame

Firefighter Training Facility

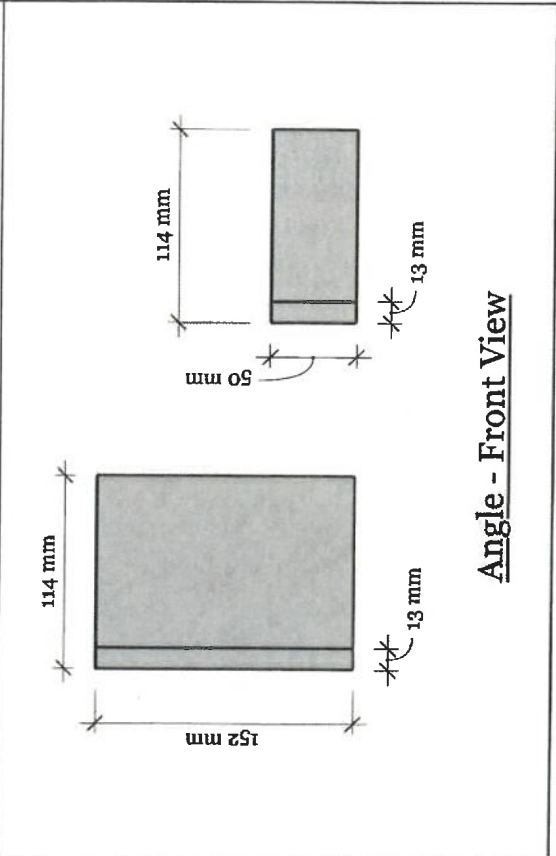
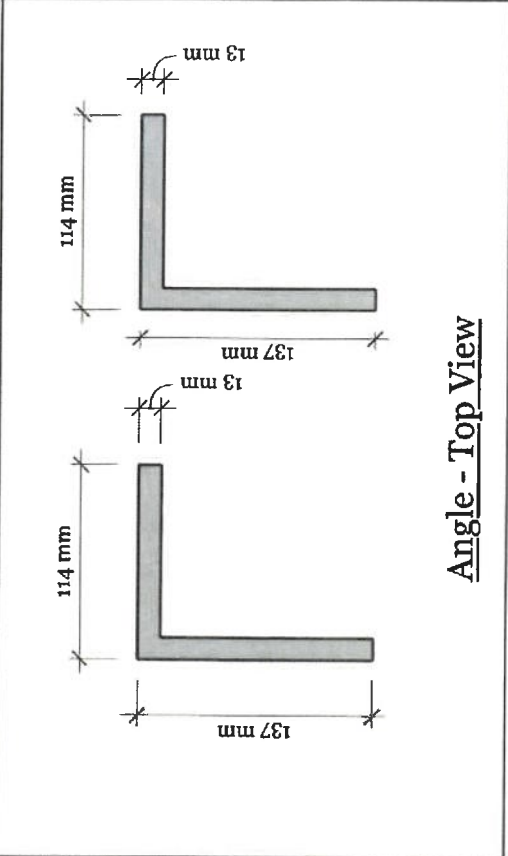
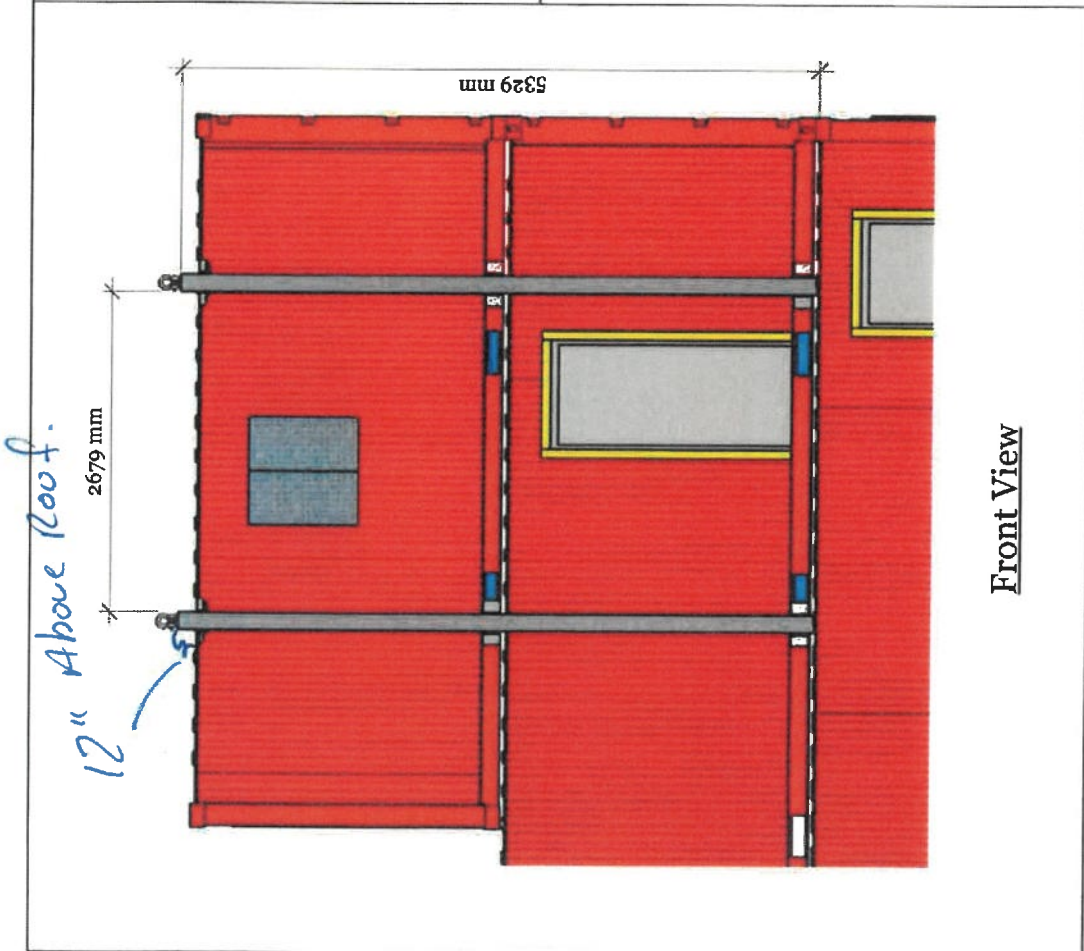

HSS Column Anchor Connections		REVISIONS	
Firefighter Training Facility		MM/DD/YY	REMARKS
		1	03/30/2021
		2	
		3	
		4	
		5	
A	11		

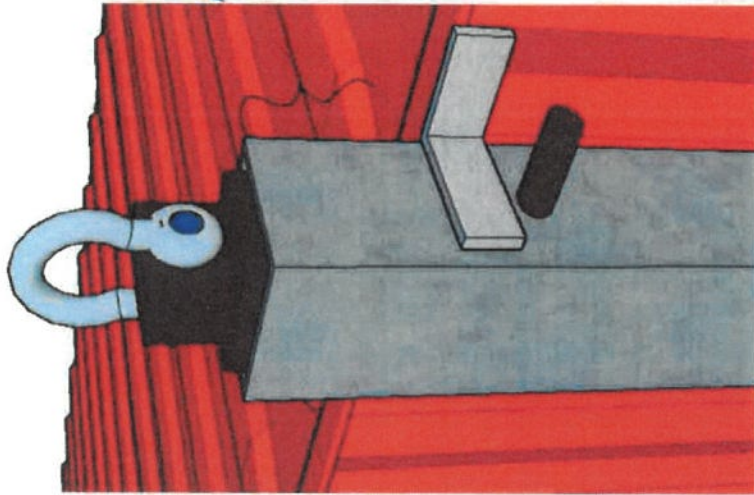

Anchor Connection to HSS Column

12" Above Roof

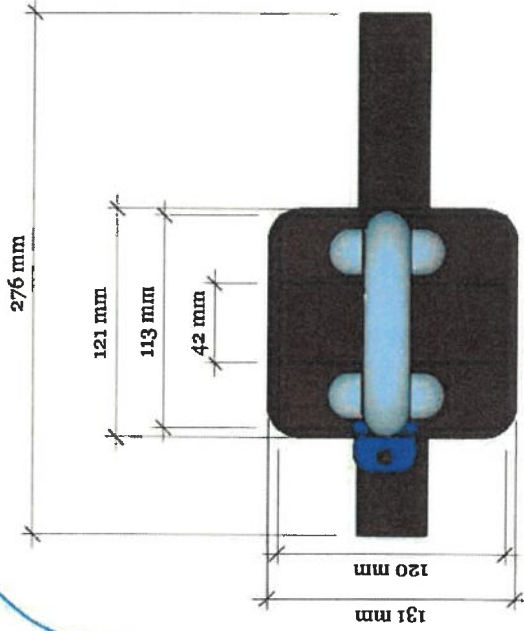

Top View - Hitch and Shackle

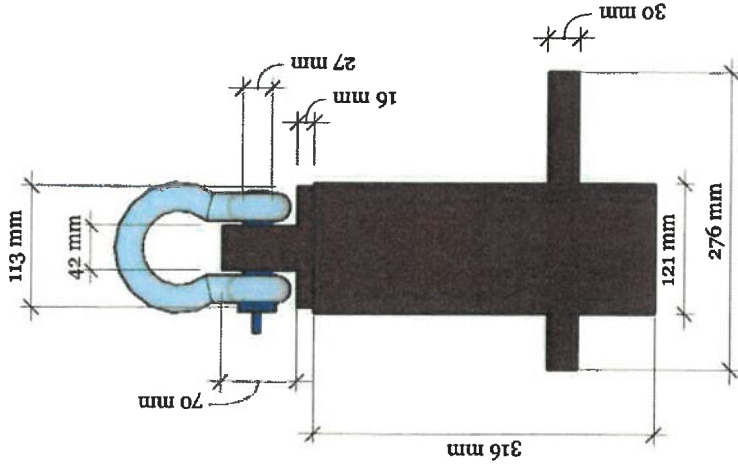

Front View - Hitch and Shackle

Tie-off Anchor

Firefighter Training Facility

REVISIONS	
MM/DD/YY	REMARKS
1 03/30/2021	...
2	...
3	...
4	...
5	...

A 12

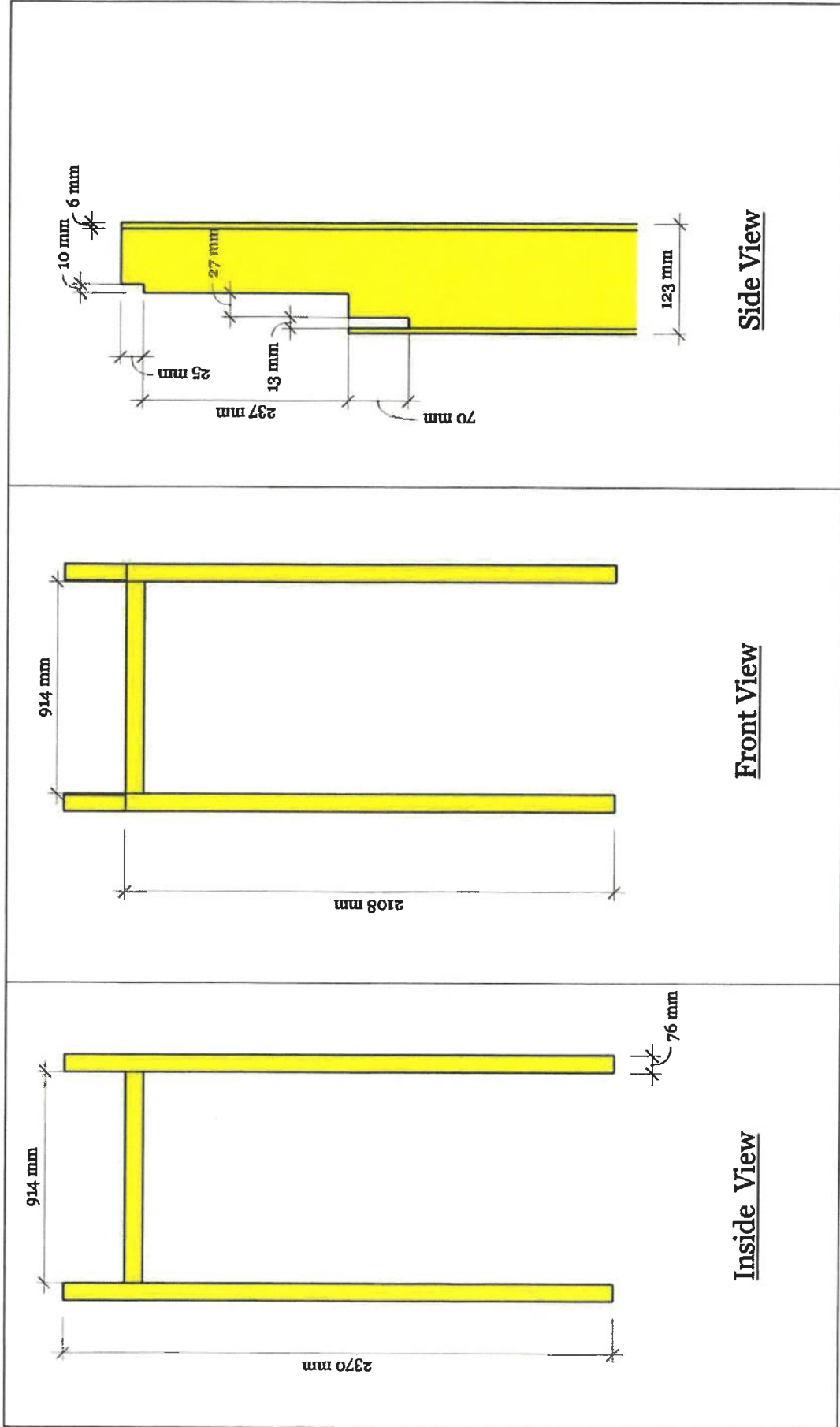

A
13

REVISIONS	
MM/DD/YY	REMARKS
1 08/30/2001	...
2	...
3	...
4	...
5	...

Firefighter Training Facility

Door Frame

*Don't want
Hole
Curt
Board*

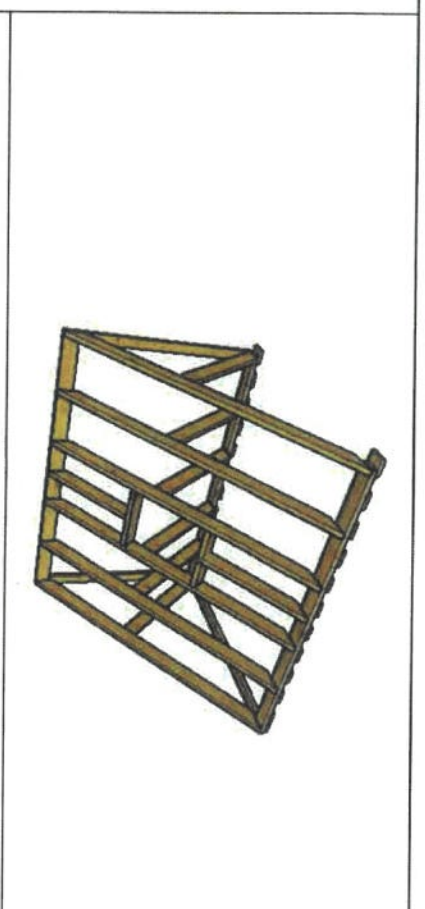
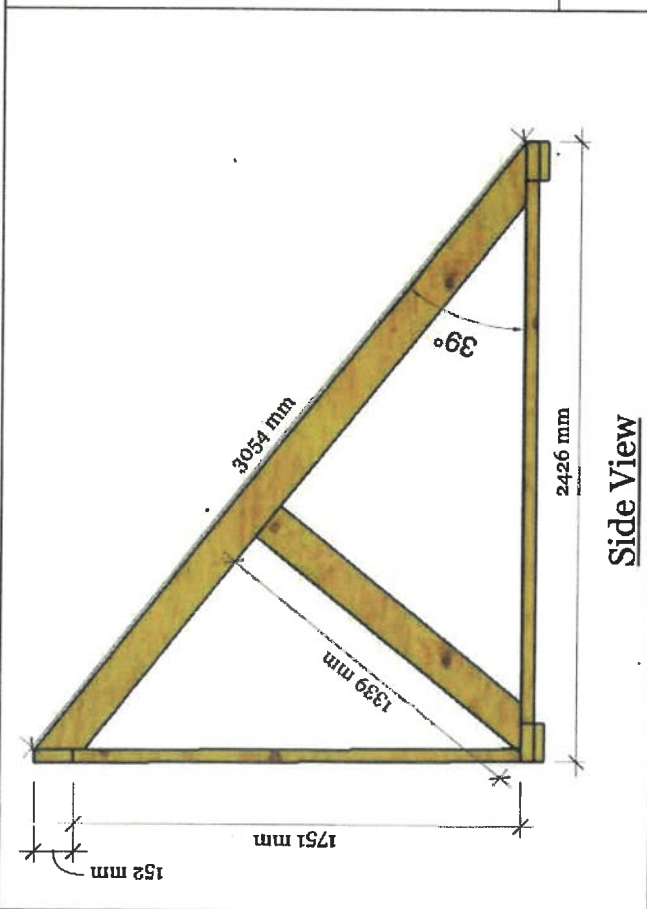
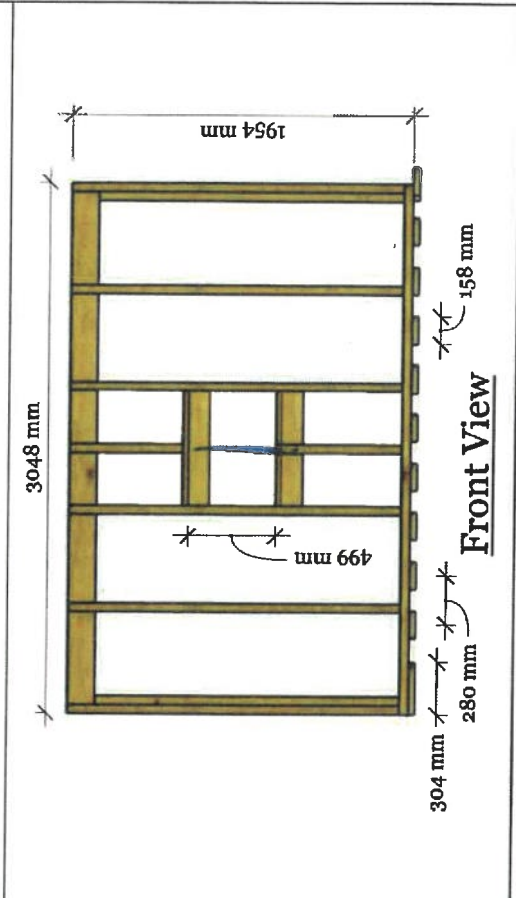
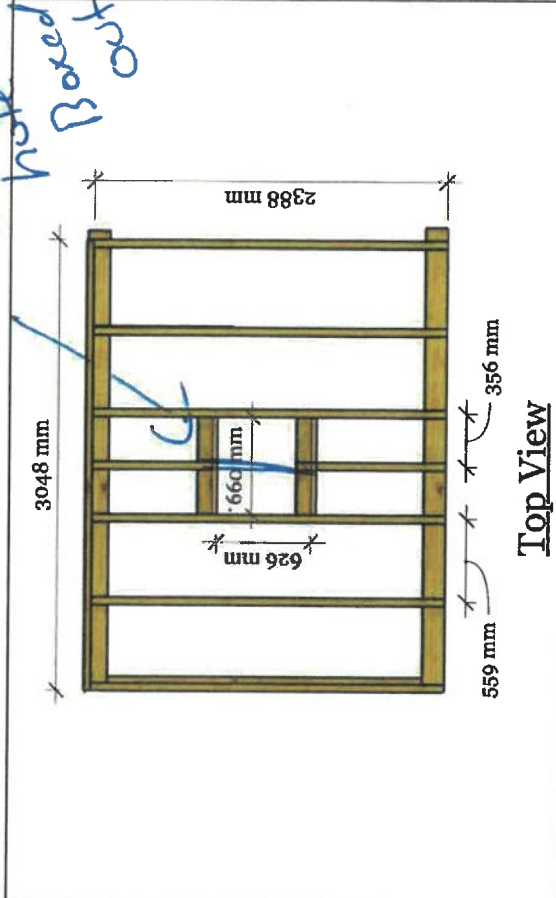

A 14

REVISIONS	
MM/DD/YY	REMARKS
1 03/30/2021	..
2	..
3	..
4	..
5	..

Firefighter Training Facility

Ventilation Simulator

This is Above BORN unit In Side C-CAR.

Welded

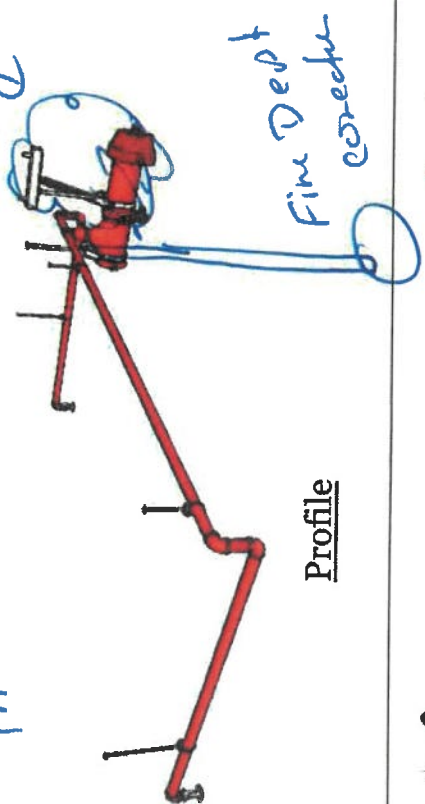

Profile

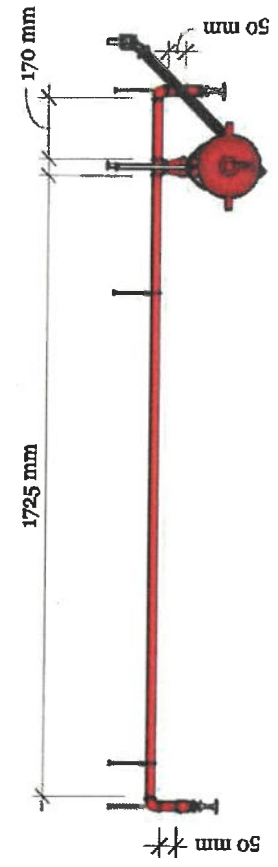

Front View

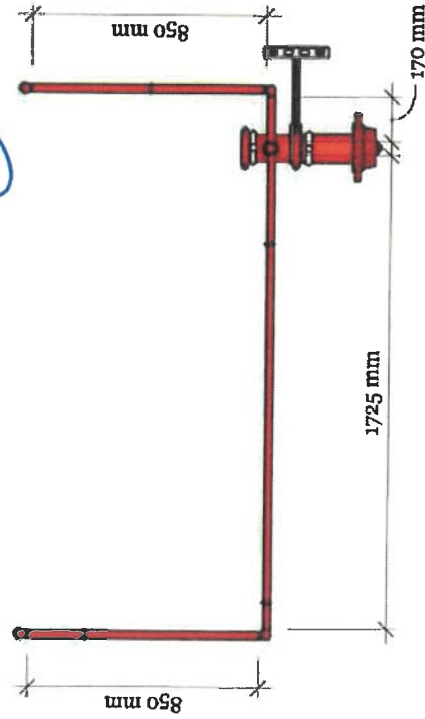

Top View

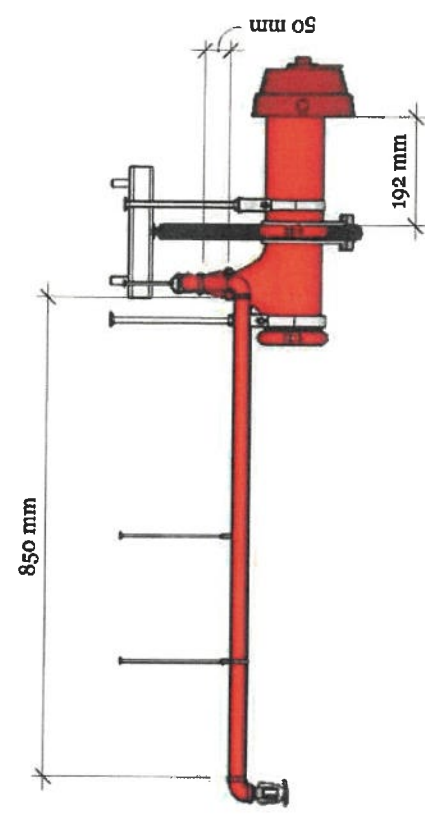

Side View

Sprinkler System

Firefighter Training Facility

A 15

REVISIONS	
MM/DD/YY	REMARKS
1 03/10/2021	...
2	...
3	...
4	...
5	...

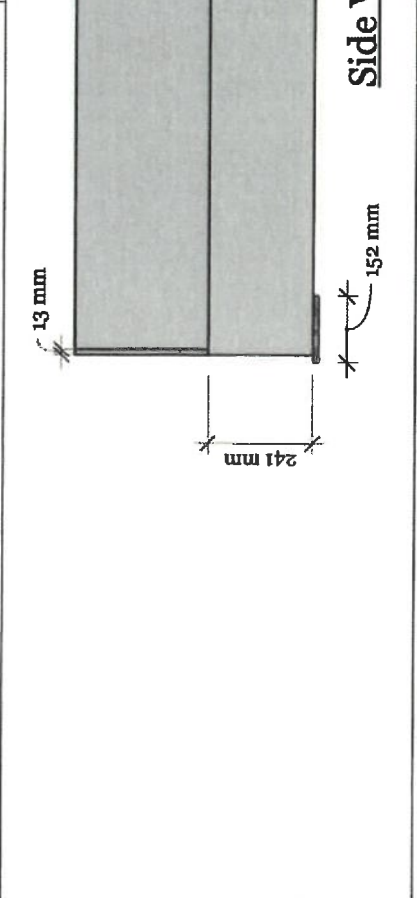
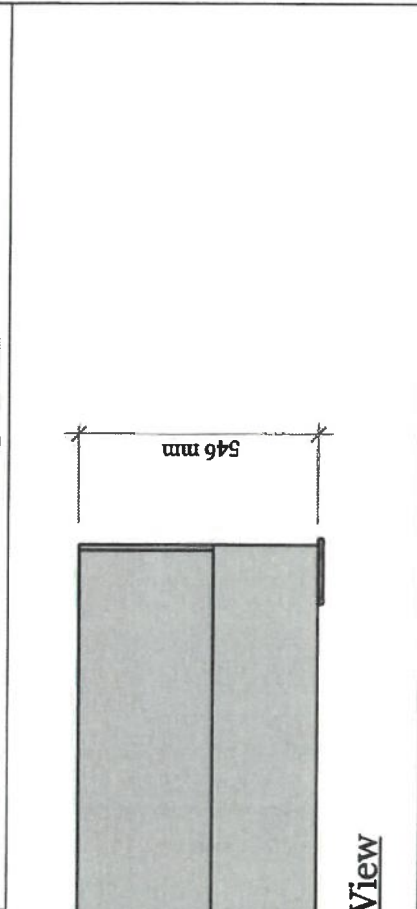
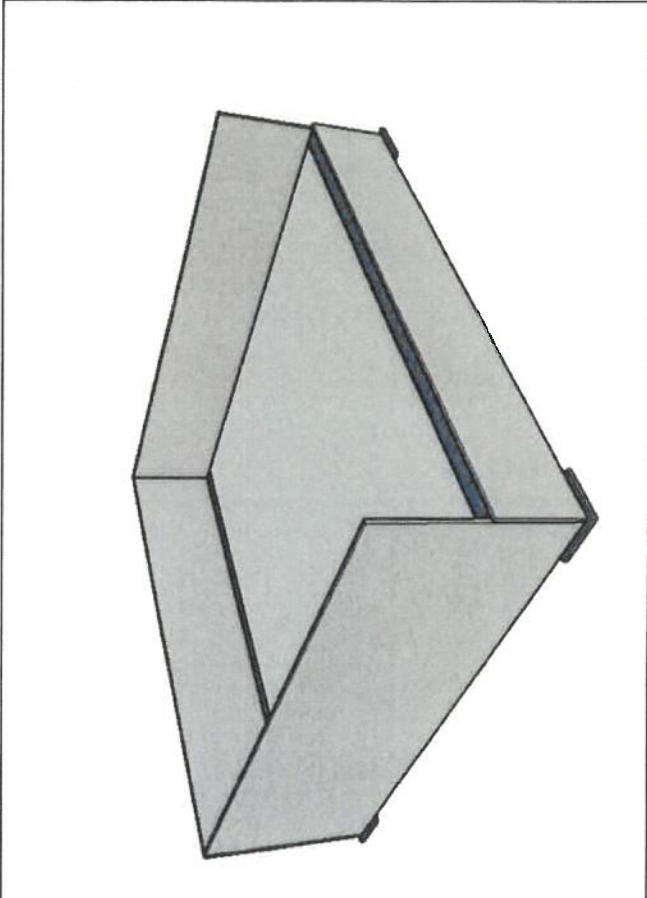
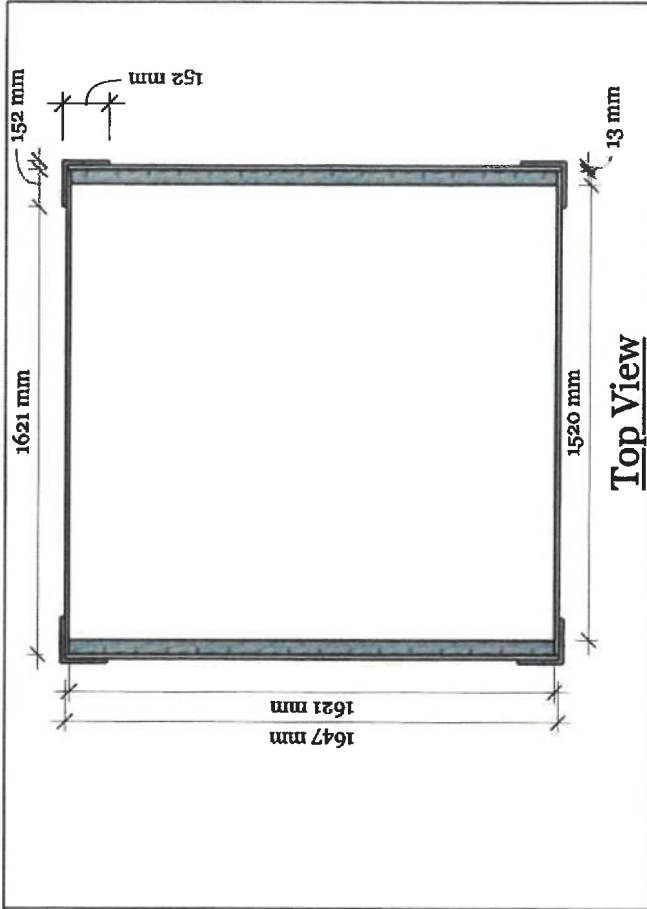

A 17

REVISIONS	
MM/DD/YY	REMARKS
1	03/30/2021
2	
3	
4	
5	

Firefighter Training Facility

Burn Frame - 2
This one.

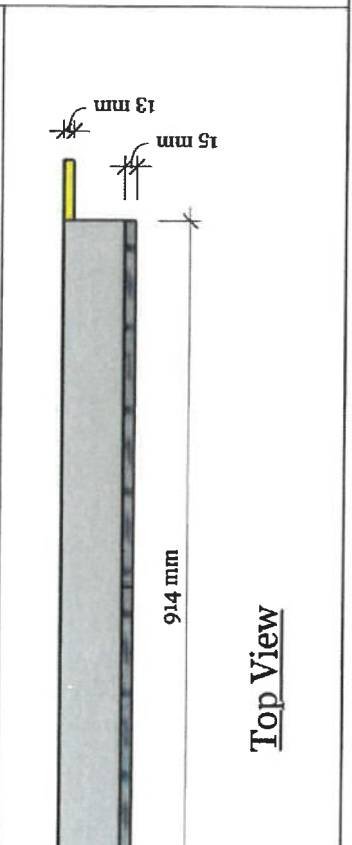
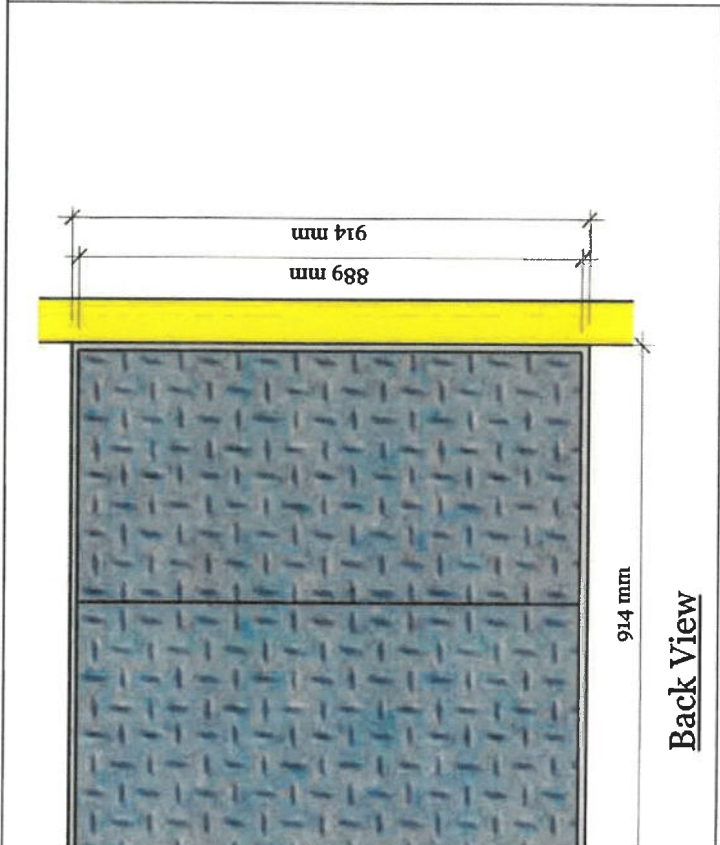
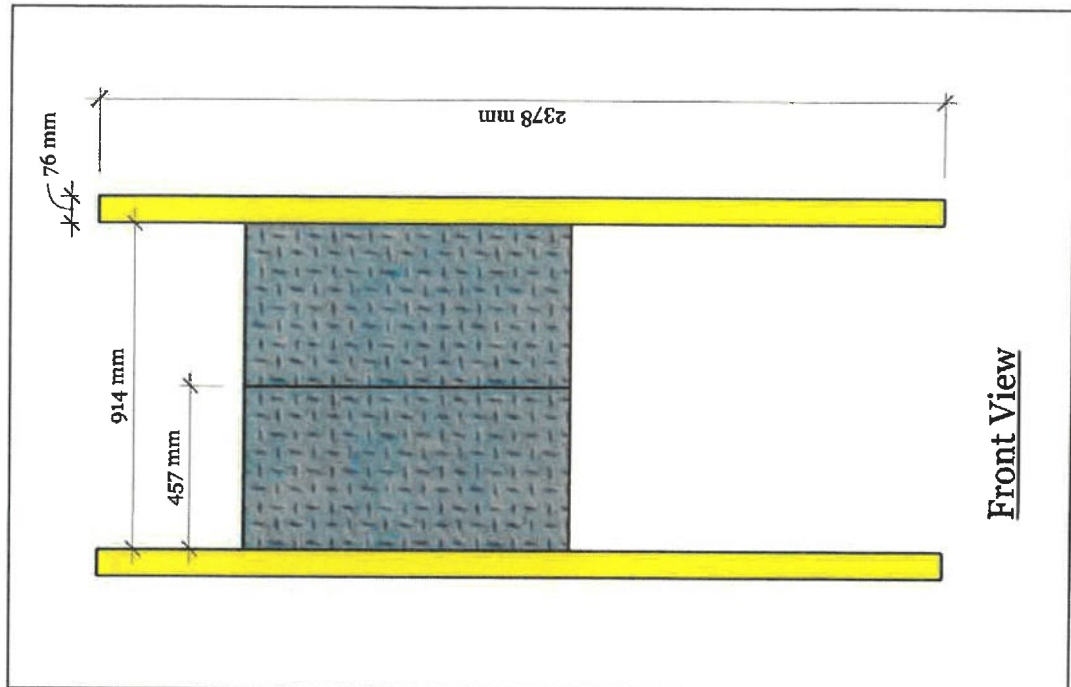

A
18

REVISIONS	
MM/DD/YY	REMARKS
1 03/30/2021	
2	
3	
4	
5	

utters/Frame
Firefighter Training Facility

new must open out.

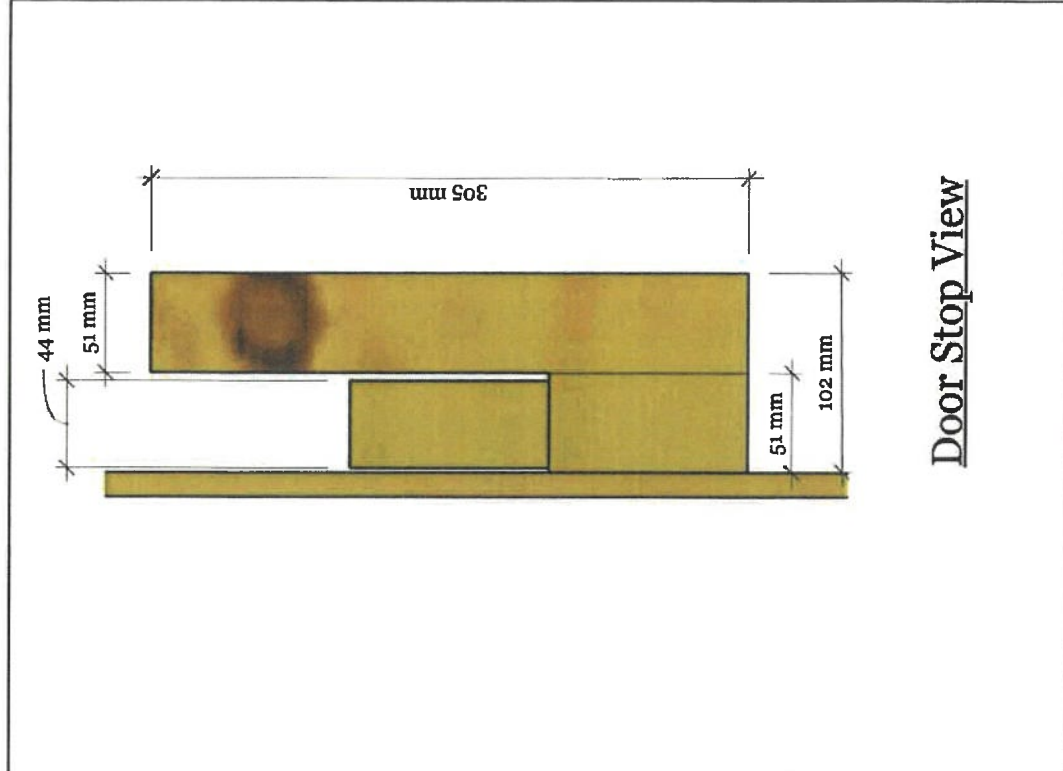

Front View

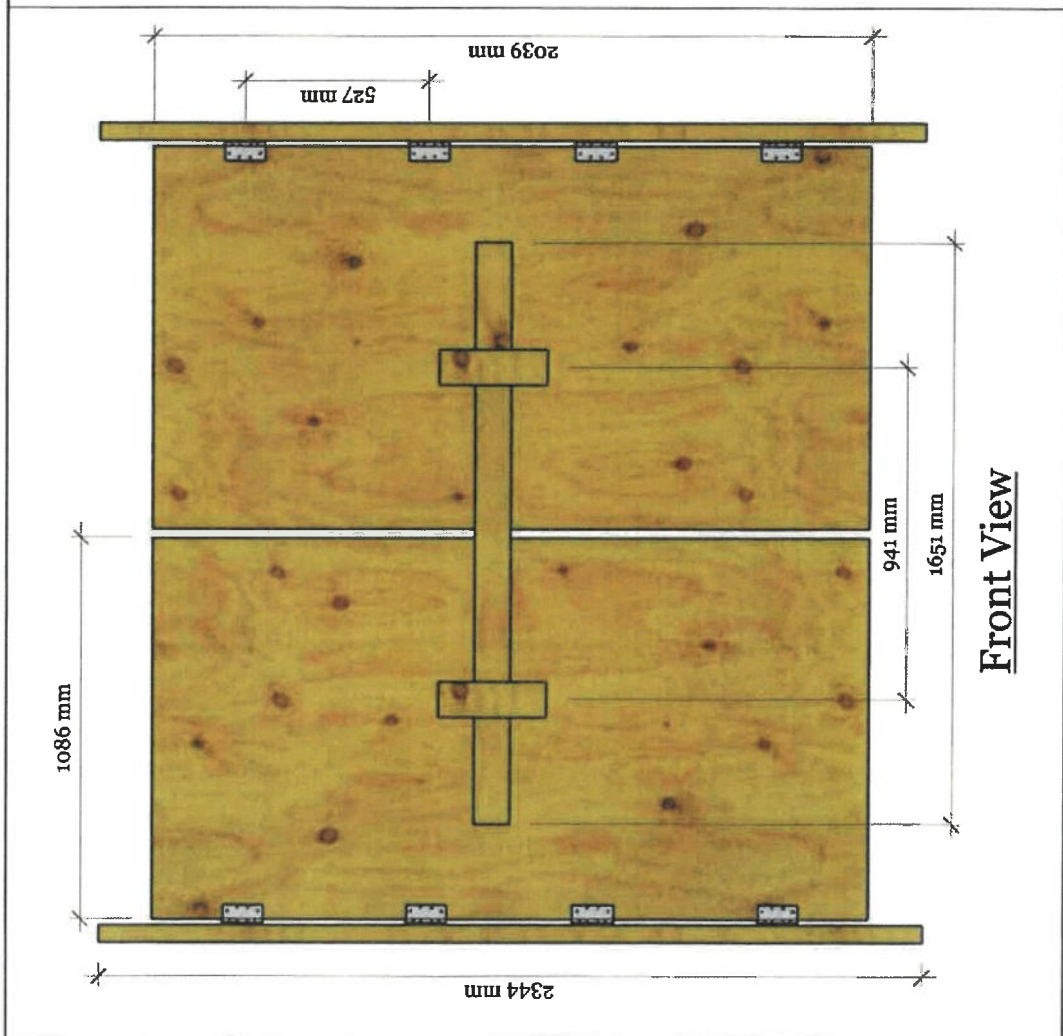

Door Stop View

A 19

REVISIONS	
MM/DD/YY	REMARKS
1	08/30/2021
2	
3	
4	
5	

Folding Doors 1

Firefighter Training Facility

3/4 Ply wood.

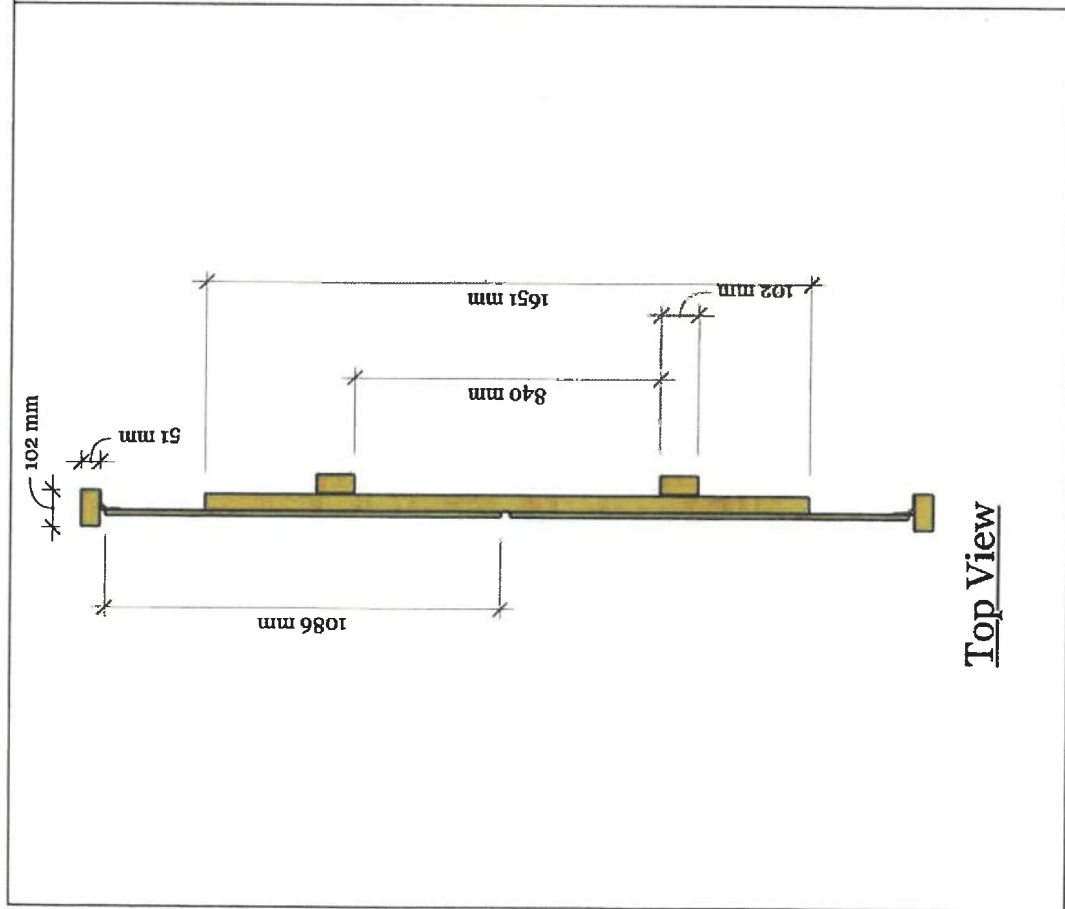

Top View

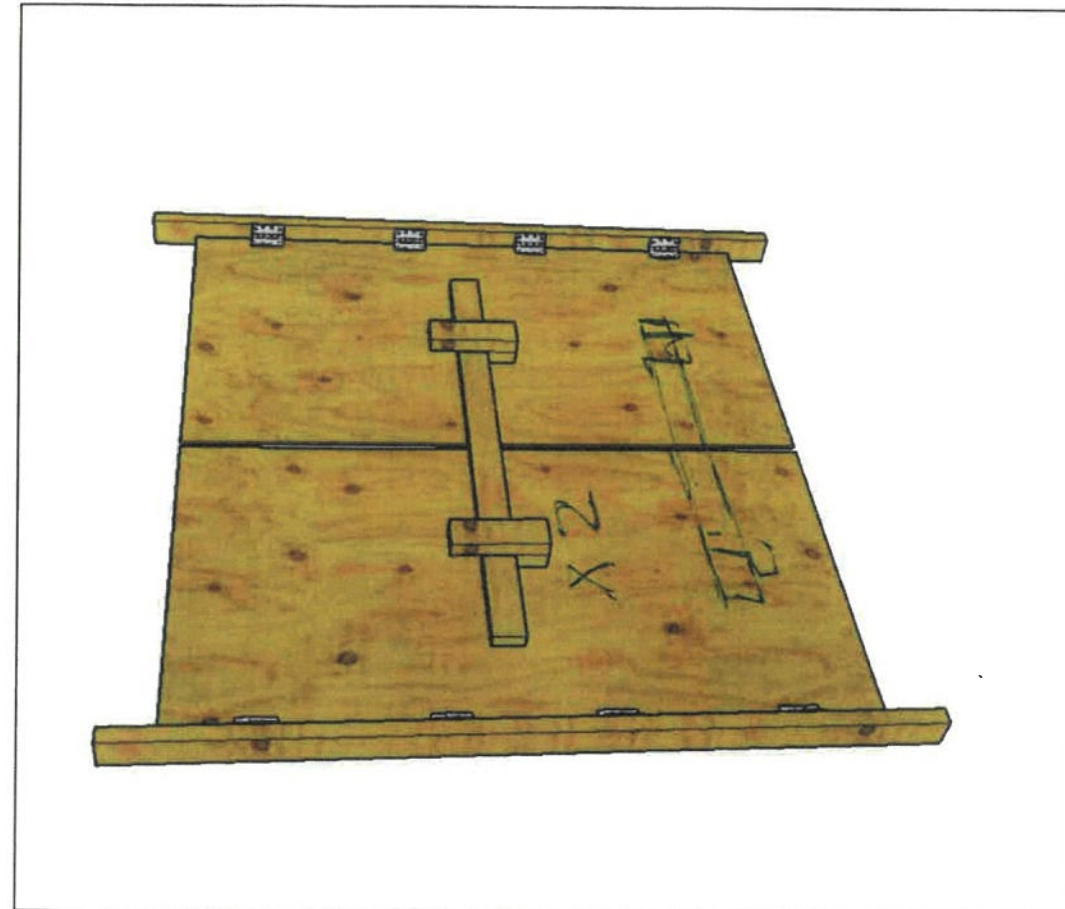

Folding Doors 2

Firefighter Training Facility

REVISIONS	
MM/DD/YY	REMARKS
1	03/30/2021
2	
3	
4	
5	

30"

1219 mm

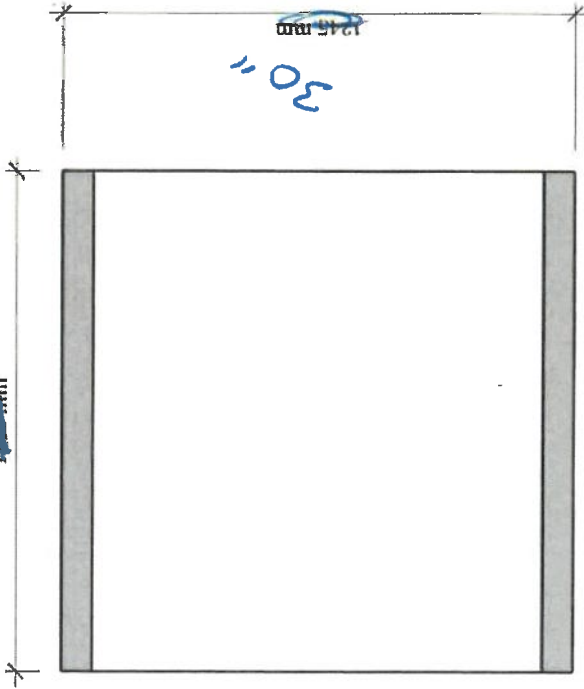

Top View

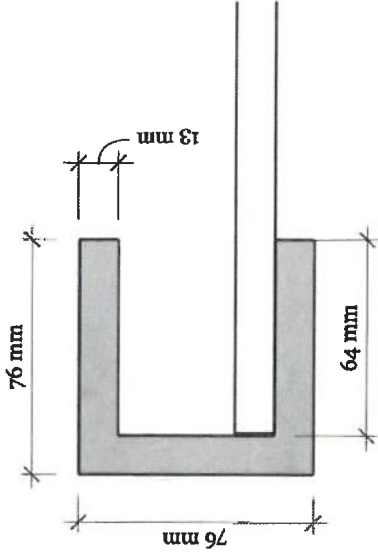

C-Channel Dimensions



Side View

Drywall Holder

Firefighter Training Facility

REVISIONS

REMARKS

MM/DD/YY	REMARKS
1 03/30/2021	...
2	...
3	...
4	...
5	...

21

A

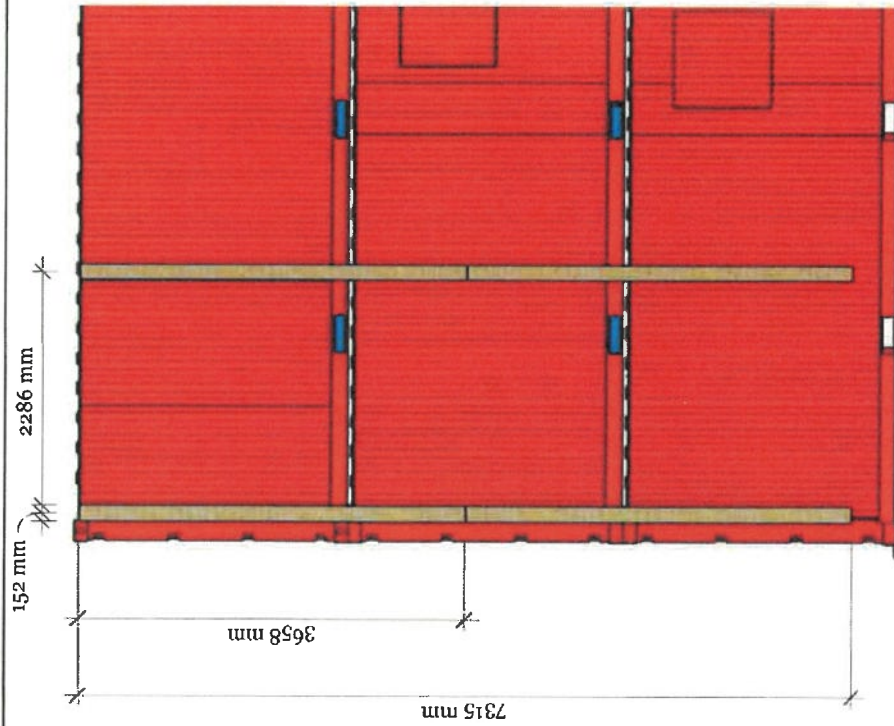

Back View - Install 2x8x12

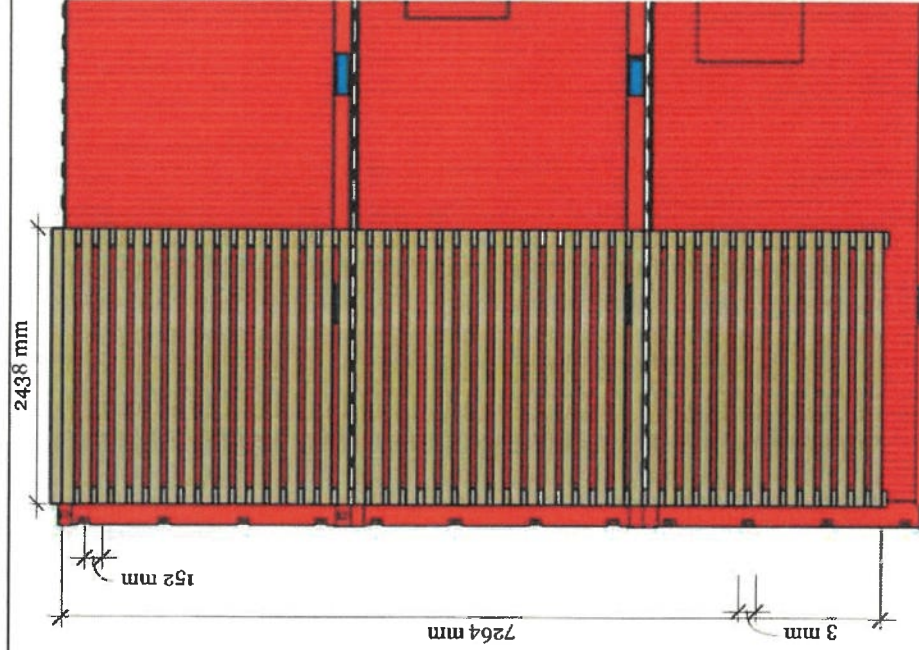

Back View - Install 4x4x8

**High Angle Rescue
Tower - Vertical**

Firefighter Training Facility

A	22
---	----

REVISIONS	
NO	REMARKS
1	03/30/2021
2	
3	
4	
5	

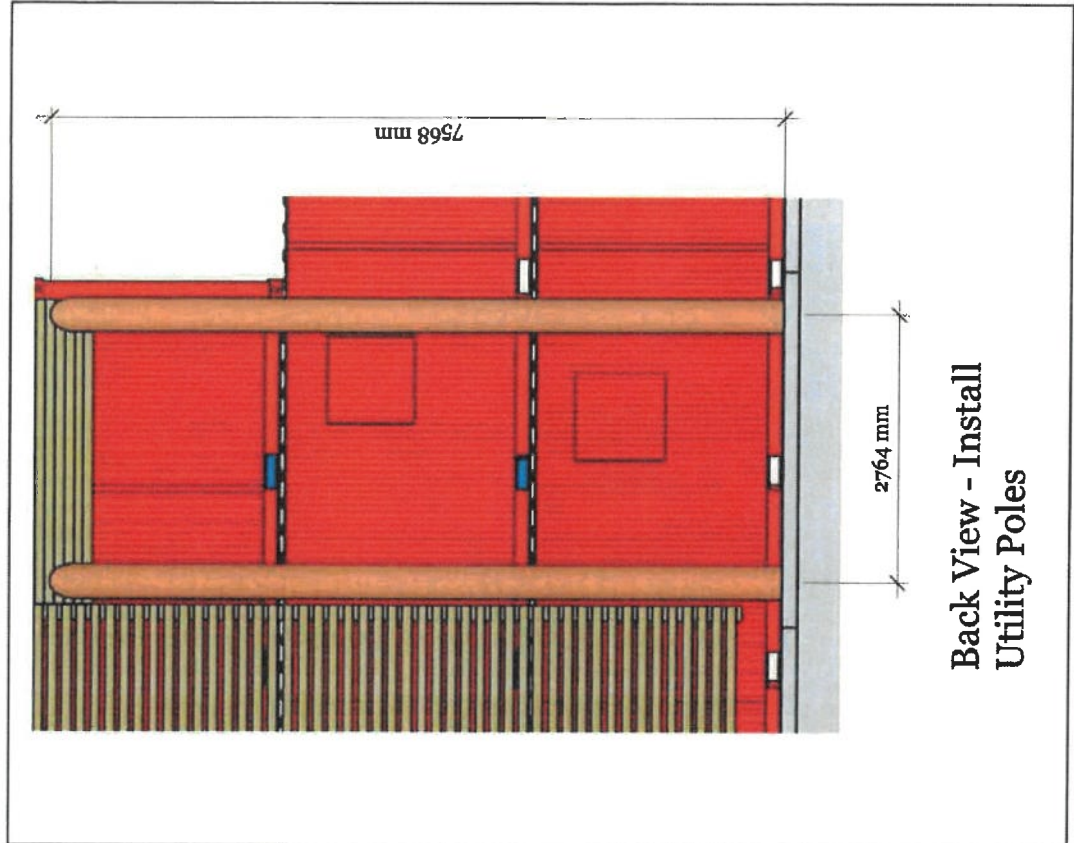

Back View - Install 4x4 to distribute utility pole load on seacan

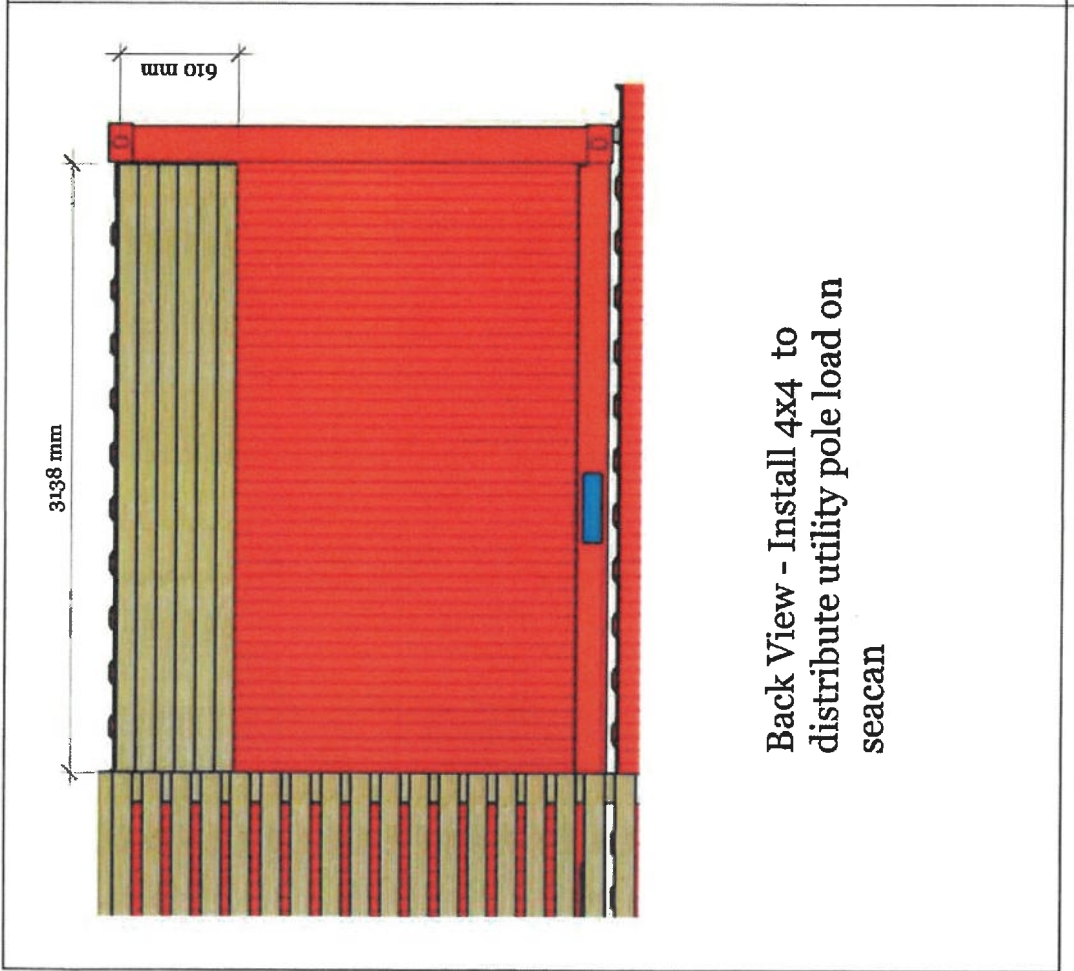

Back View - Install Utility Poles

High Angle Rescue
Tower - 45 deg - Sheet 1

Firefighter Training Facility

A
23

REVISIONS		REMARKS
MM/DD/YY	BY	
03/30/2021

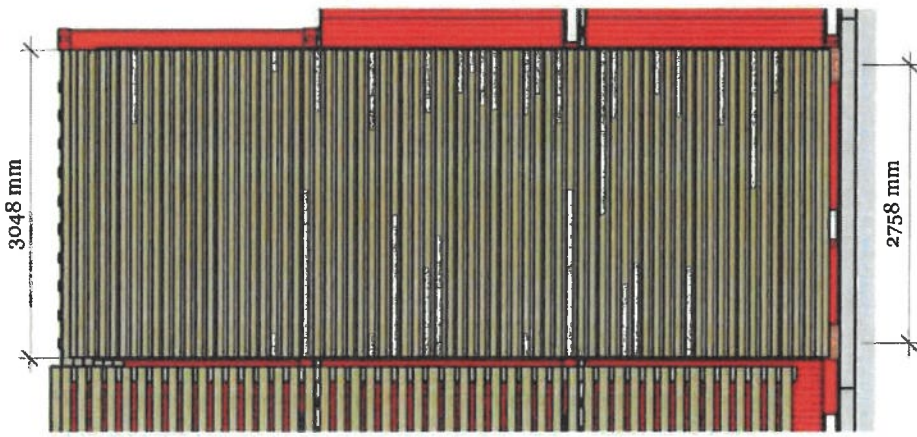

Back View - Install
4x4

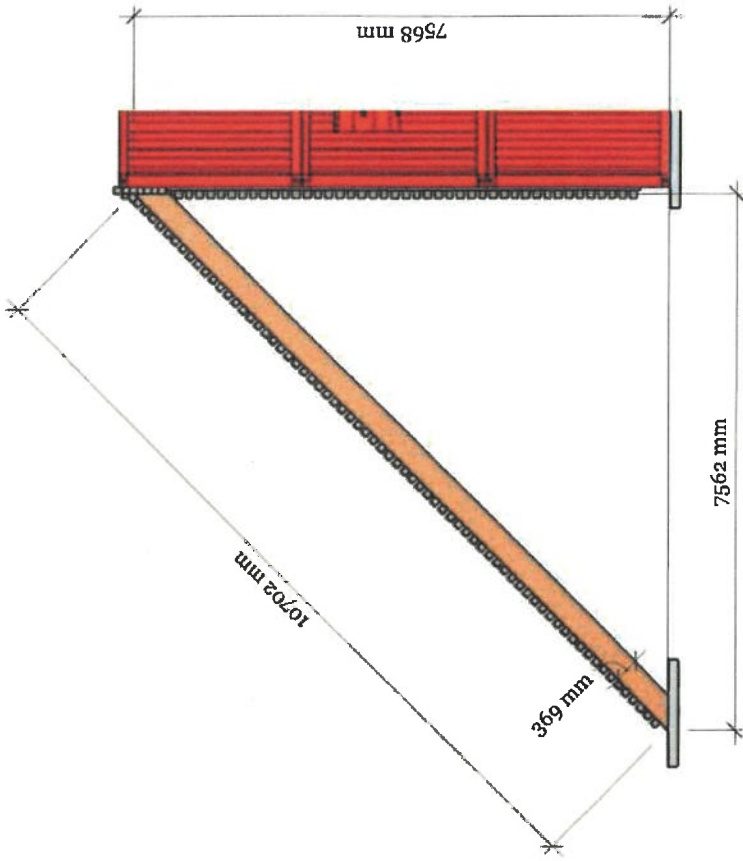

Side View

**High Angle Rescue
Tower - 45 deg - Sheet 1**

REVISIONS

MM/DD/YY	REMARKS
03/30/2021	...
	...
	...
	...
	...

Firefighter Training Facility



REVISIONS	
MM/DD/YY	REMARKS
1	08/19/2021
2	
3	
4	
5	

Level 1 Floor Plan

Firefighter Training Facility

Doors

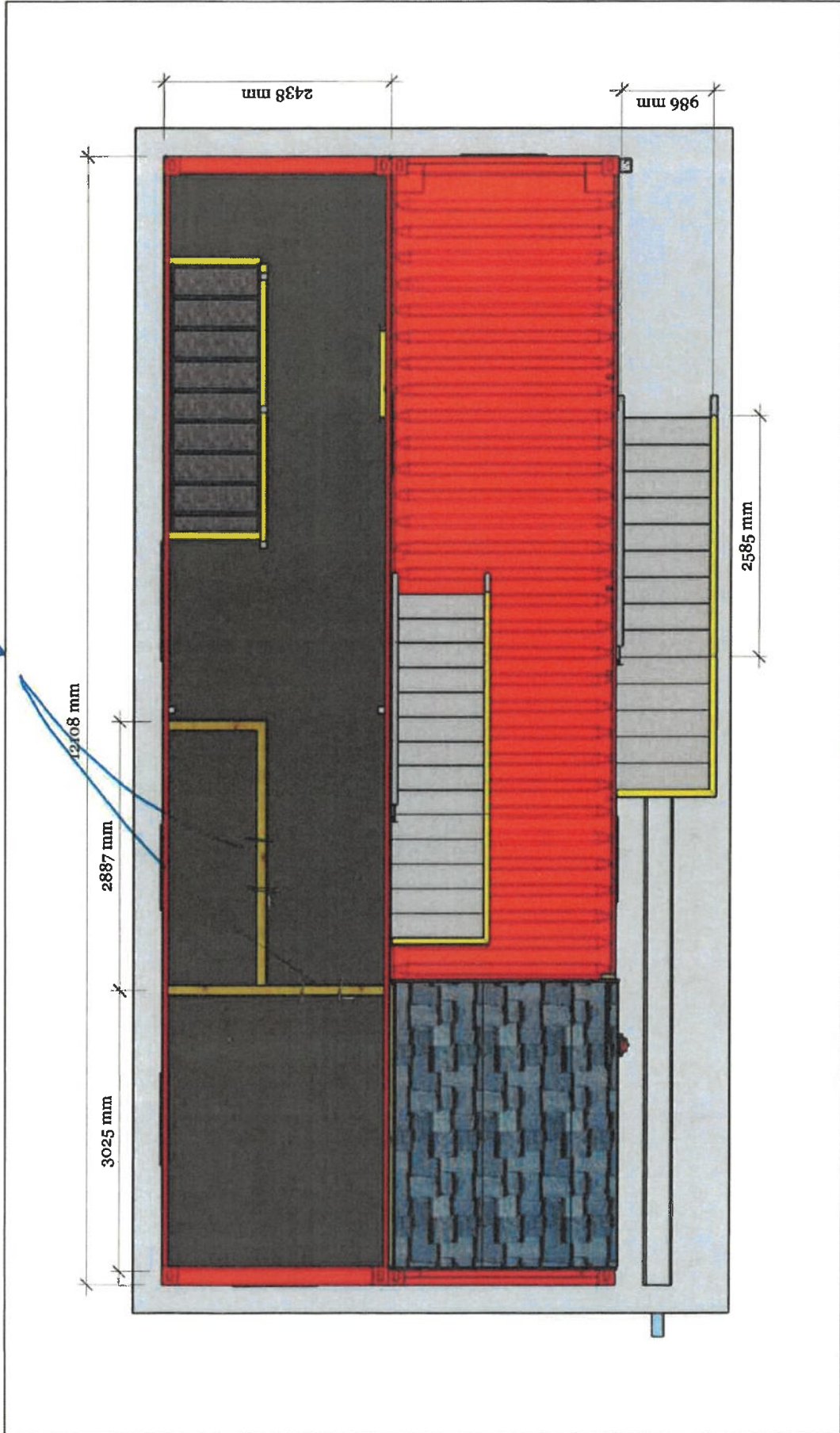

A 26

REVISIONS	
MM/DD/YY	REMARKS
1	03/30/2021
2	
3	
4	
5	

Firefighter Training Facility

Level 2 Floor Plan

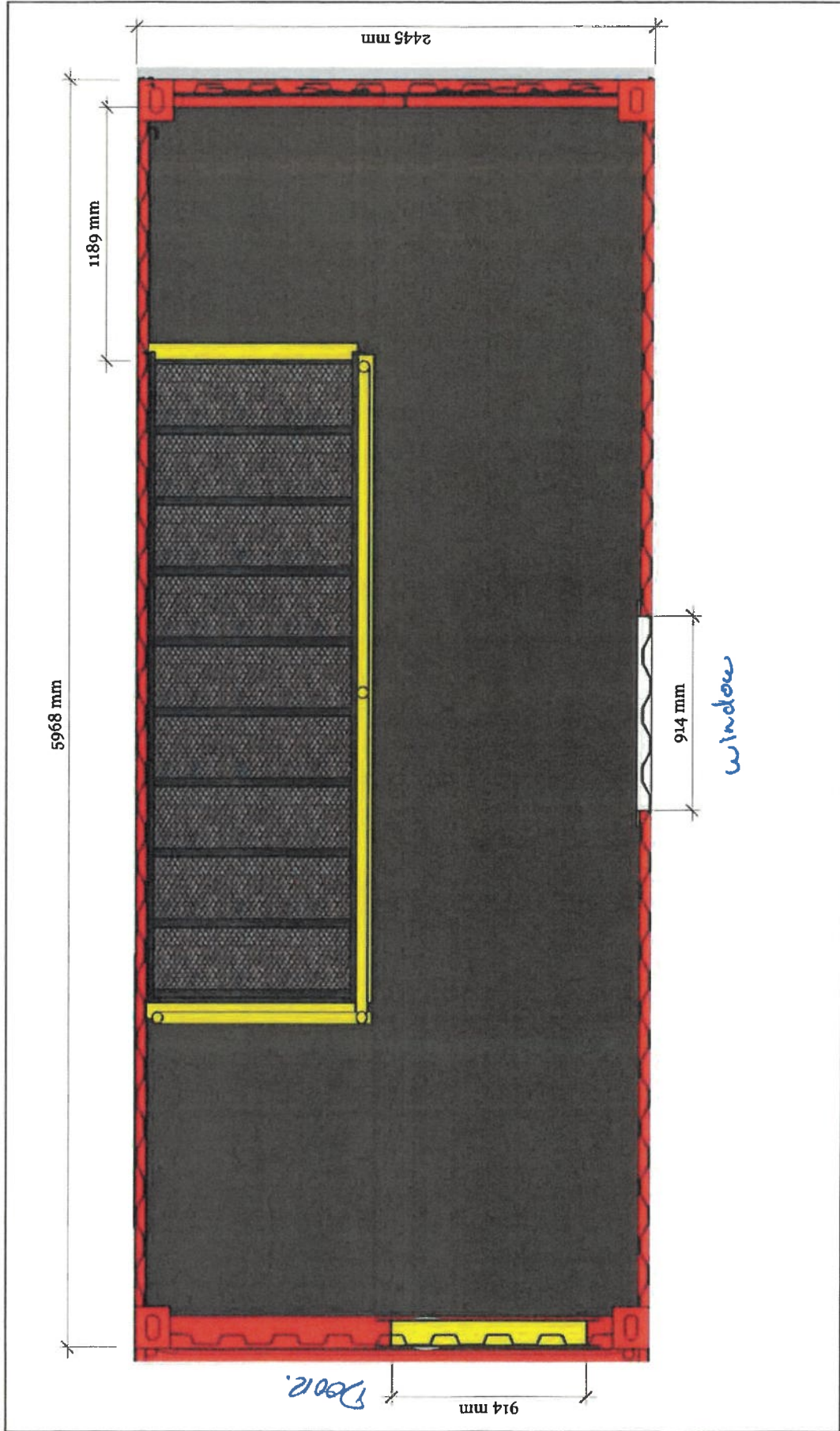

A 27

REVISIONS	
MM/DD/YY	REMARKS
1 03/30/2021	...
2	...
3	...
4	...
5	...

Firefighter Training Facility

Level 3 Floor Plan

Phase 1 – Excavation and Concrete Slabs

Step 1

- For the smokehouse slab, the entire area needs to be excavated to a depth of 18in, with a 48in wide portion along the front excavated to a depth of 36in.
- The burn pad requires excavation to a depth of 0.5m, but requires a 6in drain pipe to be laid 1m below grade.
- The drain pipe should come up in the exact center of the pad and exit towards the smokehouse slab.
- The third slab, for the base of the rescue tower ramp, will require minimal excavation, but should be scraped down several inches below grade, leveled, and flattened.

Step 2

- Next for the smokehouse and burn pad slabs, place 0.3m of Class-A gravel and compact it with hand tamper.
- Place a layer of sand on top with a thickness of 0.051m (or 2in) to protect the geotextile.
- Cover with another 0.051m of sand to protect geotextile from the top.
- The small tower slab does not require a crushed-stone base, but may be poured on the ground if it is flat and level.
- Build formwork for slabs based on specifications given in the construction drawings.

Step 3

- Place rebar or some type of reinforcement in the steel to add tensile strength.
- Pour the slabs with concrete specified at 35 MPa. 35 MPa concrete provides the required strength needed for attaching the containers to the concrete with the Power-bolt system.
- The slabs will need to be finished with their respective slopes for water drainage, and polished smooth with a magnesium trowel.
- Drainage system should be completed, fed into the ditch outside the fence, and the trench filled back in.
- After concrete has reached half its final strength (3-4 days), the forms may be removed and Class-A stone should be used to fill in around the slabs and fix the area back to regular grade.

Phase 2 – Placement and Weld / Secure Shipping Containers

Step 1

- Once the concrete slab has been cured and stripped, two 40ft shipping containers will be placed on top side by side. Referring to the construction drawings, the doors of the shipping container with the burn room in it must be placed closest to the trench in the slab.
- Both level one shipping containers will be connected to the slab using 130x110mm sized angle irons of two lengths. The four corners of level one will be connected using the 10mm thick angle irons that are 150mm long.
- The angle will be welded to the shipping container corners and bolted to the concrete using two concrete Power-bolts per angle.
- The same size angle at 270mm length will be placed where the two container corners meet in the middle of the structure and be connected the same way as the corner connections.

Step 2

- The second-level shipping container can be placed and welded as detailed in the construction drawings.
- The three corner connection will have 500mm of 10mm weld and the two corner connection will have 370mm of a 10mm weld.
- Once the second level container is secure, the 20ft container supports must be installed before the third level container can be put in place.
- Two 3x3in HSS columns, 2419mm long, are installed close to the walls at the midpoint of the level two container.
- Columns should have a 5x5in base plate to distribute column load to the plywood floor.
- Two small holes must be cut into the roof of the container for the column to pass through and connect to the base corner of the container above.
- Both columns will be welded to the corners using 6in long 10mm welds shown in the construction procedure.
- The two other corners of the 20ft container will be welded like the two corner connections on the previous level. They will be connected by 370mm of 10mm welds as shown in construction procedures.

Phase 3 – Rope Rescue Anchor Points and Grating

Step 1

- Two 6x6in HSS columns must be secured to the side of levels two and three on the front of the structure. This will support the anchor tie-off connections for high-angle rescue training on top of level three.
- Both members will be connected at six locations.
- Angle sizes are the same for all connections which are 114x137mm by 13mm thick.
- The base connection and the midpoint connection of the columns are using angle lengths of 152mm and fit into the main structural beam at the bottom of the level two and three containers.
- The top connection angle is only 50mm long since it has to avoid the pin connection location and will be welded to the 50x50mm beam at the top of the level 3 container.
- There will be twelve angle connections for each column and all connections will be welded.

Step 2

- The KFI Product drawbar with a shackle described in Section 5.6.1 can handle a load of up to 10,000lbs.
- This product must be adjusted from needing a 2in receiver to a 5.5in receiver so that it can slide and be secured in the HSS column.
- 30mm holes must be drilled into the HSS column and a pin will slide through to hold the hitch in place.
- The sizing detailed in the construction drawings allow for the anchor point to be 6m above the roof of level three and positioned directly across from both the high angle rescue tower openings in the railing.

12" →

Step 3

- 4x8ft pieces of the metal grating are the next component to be installed as a walking platform.
- The level one shipping container is covered in grating up to the ventilation simulating to be built in the following step.
- The roof exposed on level 2 and the entire roof of level 3 is also to be covered in the metal grating.
- All metal grating can be welded to the longest roof beams of each container.

Phase 4 – Ventilation Simulator

Step 1

- The first step of phase 4 is to cut a 2ft square hole in the roof of the burn room with angle grinder.
- The frame of the ventilation simulator is to be constructed out of 2x6 and 2x4 pieces of lumber.
- The roof of the shipping container is corrugated so blocks must be placed in between the corrugation in the roof in order for a 10ft long piece of 2x6 lumber to run level with the roof. This must be done on the inside edge and front edge of the level one roof.
- A 2x6 is also bolted to the wall of the level 2 container at a height of 1930mm for the rest of the framing to be done.
- Carpenters can refer to construction drawings for measurements on the rest of the framing.

Step 2

- After framing is complete, six, ^{3/4}5/8in T&G Plywood sheets are needed to cover the roof and sides of the frame.
- Aluminum J-trim is installed vertically and along the slope of the roof to cover the edging of the aluminum siding being installed next.
- Install Aluminum framing on walls using 5/8in self-tapping screws to the sides of the ventilation simulator.
- Shingles are nailed to the roof.

Phase 5 – Railing and Exterior Stairs

Step 1

- The rails are designed to meet industrial height standards and can be fastened at the base to the steel metal grating.
- The stairs to the roof of level one can be installed first and then the railing around the edges of level one roof.
- The rail around the ventilation simulator is fastened to the frame along the front side of level one and welded to the roof beam along the left side. Note this section of railing is on the same slope as the roof and all rails are above and running parallel to the angled roof.
- The second exterior staircase is then installed to access the roof of level two and the railing is fixed around the edges and secured to the metal grating.
- Carpenters can refer to construction drawings for measurements on the rest of the framing.
- The ladder for accessing the level three roof is fastened to the beam of the level three roof as well as the railing posts on top of the 20ft container.
- Level three roof railing is also fastened to the metal grating. Please refer to construction drawings for railing dimensions and openings in the railing.

Phase 6 – Windows, Doors, and Interior Stairs

Step 1

- Window and door holes are cut out using an angle grinder at locations specified in construction drawings.
- 3x3ft openings for windows and 3x6.7ft openings for doors are needed to fit both frame and door.
- The windows are framed out of 12.5mm thick metal and have a width of 3in to extend slightly out of both sides of the corrugated walls.
- This extension allows a flat piece of metal to connect to the sides of the window frames and be welded on the top and bottom beams of the container for strength. The window frame width also allows enough space for a hinge to connect the shutter to the frame.
- There will be two shutters per window and a simple ring latch will be on the inside for secured closure and ~~on the outside on the walls of the container to keep them open.~~
- The exterior door frame is made out of 123x76mm C-channel and should be fabricated in accordance with the door frame detailed drawings. The two vertical channels will be installed first and will be welded to the top roof beam and floor beam.
- Then the horizontal C-channel can be put up in place and welded to the vertical pieces of the frame. The vertical C-channel is designed so that the water buildup in the horizontal piece can flow out through the vertical through an opening to avoid water pooling.
- Industrial doors are to be installed and welded to the door frame C-channel.
- The inside doors between the level one containers are the same sized doors and C-channel but the C-channel framing is designed slightly differently.
- The outside doors only have the frame connected to the roof beam on the inside of the container, the inside frame is designed to have the frame extend up to the roof beam in both shipping containers.

Step 2

- Stair holes should be cut out and framed up with the same sized beams that were cut off.
- The blue beams shown in the construction drawings are the installed beams to support the stair hole.
- 3x3in HSS columns should also be placed to provide extra support for the previously installed floor beams.
- The thin C-channel 239x79mm is to cover the installed floor beams and cover the gap between the floor and the roof of the containers.
- After the finishing of the stair cut-outs, steel stairs with rails will be installed and will be bolted to the installed floor beam and the floors of the containers.
- Both stair cut-outs are similar, and welders should see construction procedure documents and construction drawings.

Step 3

- More interior work includes installing the folding doors and framing up the walls of the level 2 storage room and bedroom.
- The folding doors are located in the middle of the two bottom containers and the 2x4 frame is bolted to the walls of the container.
- The doors are made of plywood and fastened to each 2x4 frame using 4 hinges.
- The doors are secured while they are closed using a piece of 2x4 being lodged in the holders on the plywood shown in the construction drawings.
- The doors can be easily opened and kept open by simple ring loops attached to the container walls.
- The storage room and bedroom in level two are framed out of 2x4 at 16in spacing.
- After being sheeted over with plywood, regular doors can be installed, one for the bedroom and one for the storage room, door and wall placements are shown in drawings.

Step 4

- The burn room will be under the ventilation simulator constructed earlier.
- 10ft of the plywood floor of the container will be removed and replaced with the same metal grating that was installed on the roof.
- This metal grating will sit directly on the floor beams of the container and water and debris will run through the grating onto the slab and run in the direction of the slope towards the trench in the slab.
- Next, the drywall holder is installed so that the centre of the 4x4 sheet of drywall is aligned with the centre of the hole in the roof.
- The 76x76mm C-channel holders are fastened to the roof with bolts and with placed slightly more than 4 feet apart so drywall can slide in and out easily.
- A sprinkler system is then installed on the roof of the container.
- The hose connection sits in the wall on the front side of level 1 and goes directly into a T-pipe to distribute water to two sprinklers.
- The dimensions of the piping can be seen in construction drawings and it is shown how the pipes are connected to the roof with rods.
- The burn frame is welded using 2x2in angle iron and is a 1621x1621mm square frame that sits 241mm from the floor.
- To reduce heat being absorbed into the container walls, sheet metal is installed on the top of the frame and around all sides.
- The side facing the door of the burn room will only have sheet metal up the top of the burn frame, the other three sides have sheet metal extending 1ft higher than the top of the frame.

30" x 30"

welded.

30" APART

(Burn Room)

Fine Dent Connector

36" off concrete.

Phase 7 – Attach High Angle Rescue

Step 1

- First, install 4 pieces of 2x8 vertically on the backside of the structure for the full vertical rope rescue.
- The 2x8 lumber is bolted to the sides of the container walls and 4x4s are bolted horizontally to the 2x8s at 152mm spacing.
- Then 4x4 lumber is installed on the exterior of the level three shipping container using 4.5in flat head lag bolts with 1in washers and locknuts.
- These six 4x4 distribute the load from the utility poles as the poles will be fastened to the 4x4 and container walls using 6in and 16in $\frac{3}{4}$ wood screws.
- Utility poles are placed on a 45deg angle and also have to be secured to the small concrete slab using 6in long $\frac{5}{8}$ in Power-bolts.
- After poles are successfully connected, 4x4s are screwed to the utility poles at 152mm spacing.

Construction Sequence

Fire Fighter Training Facility



1

Phase 1: Excavation and Concrete Slabs

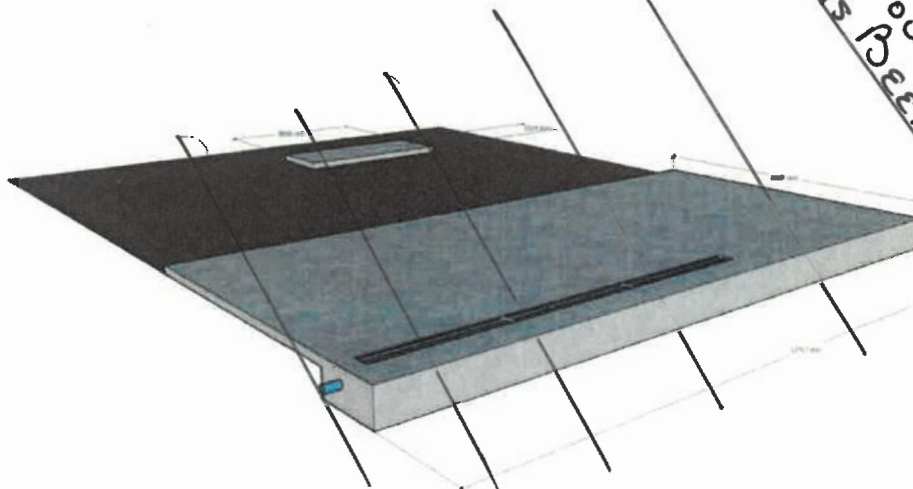

*DISREGARD
Foundation
HAS BEEN Completed*

2

Correct Placement on Slab

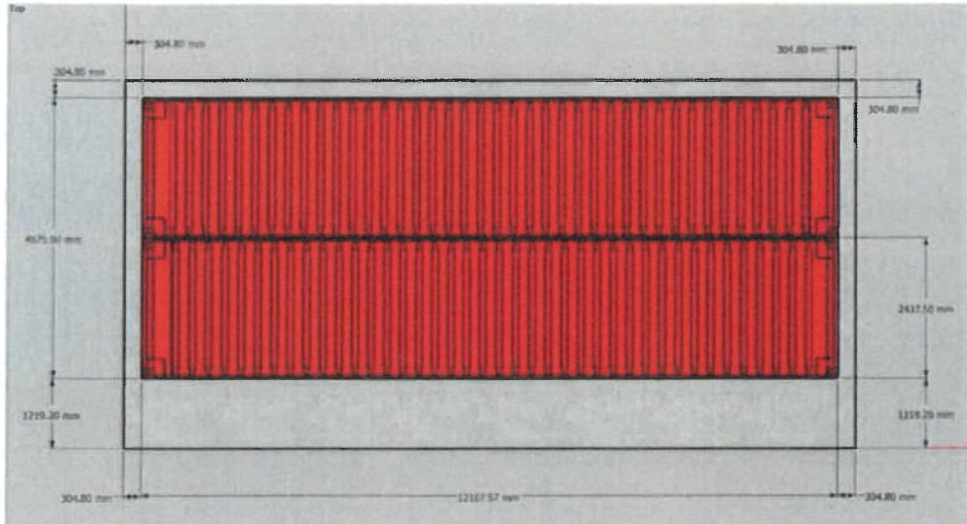

5

Install 3x3 HSS up through roof to support 20' can at Midpoint

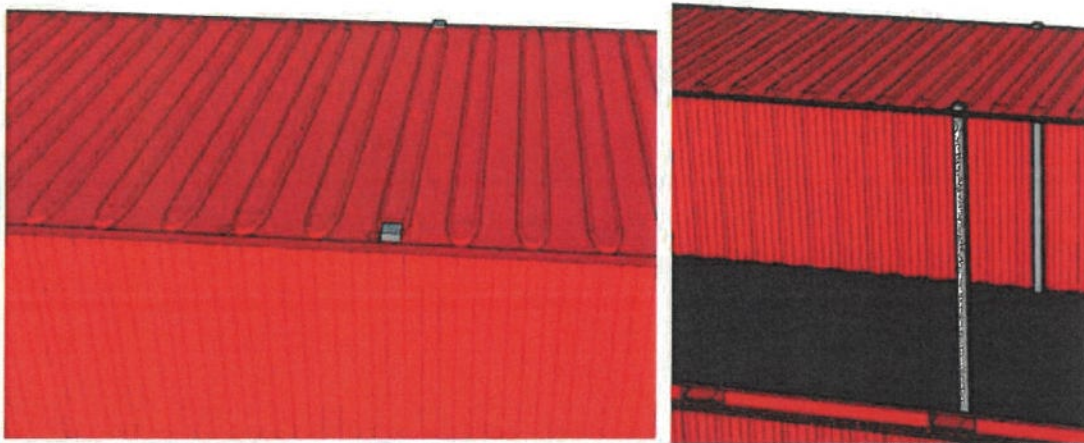

6

Place 20' Container on top after 3x3 HSS have been installed

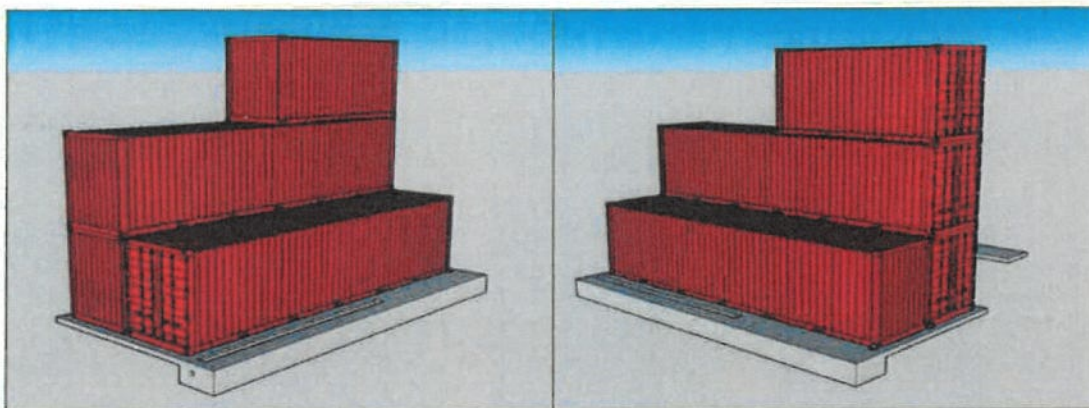

7

Placement of Container on HSS corner posts

Place 20' Container carefully on HSS supports. HSS supports require a 5x5" steel base and should be either tack welded to the interior wall or self-tapping screws used to secure the HSS beams from the exterior.

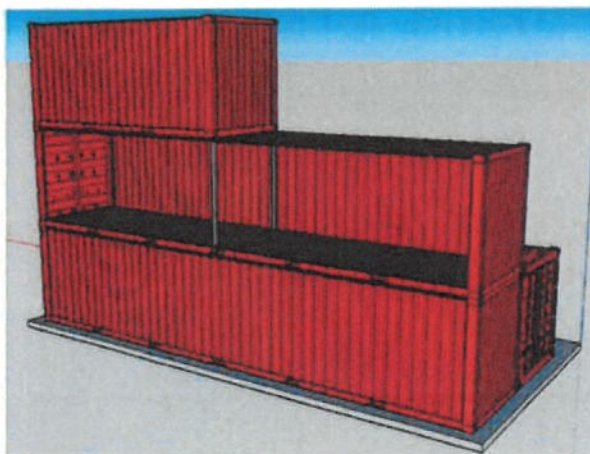

8

Weld 20' Container to HSS Corner Posts

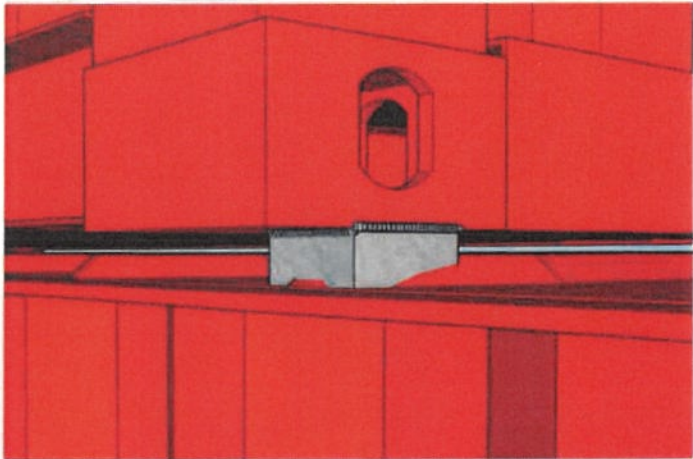

9

Level 1 Connection to Slab

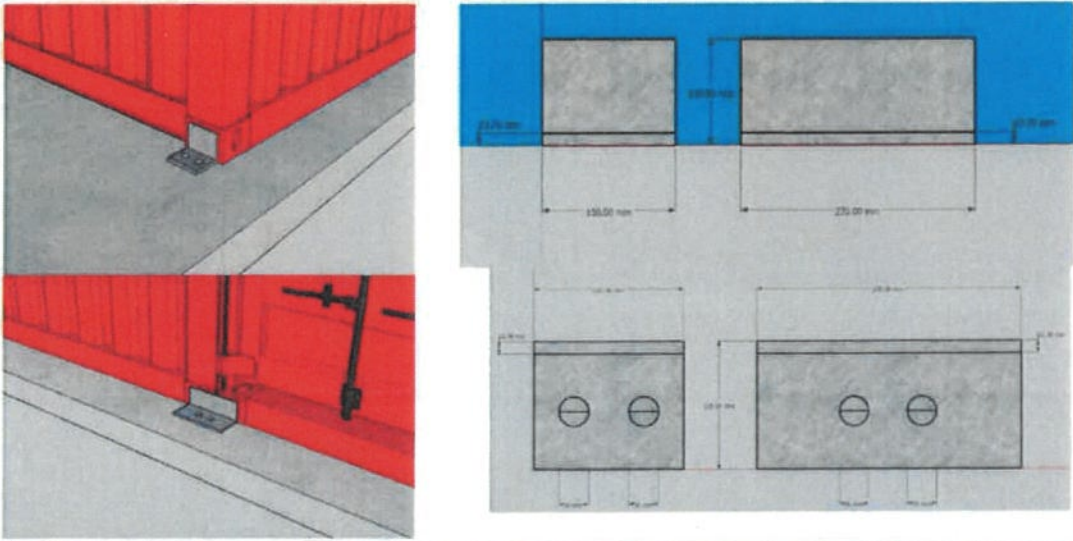

10

Welded Connections Between Level 1, Level 2 and Level 3

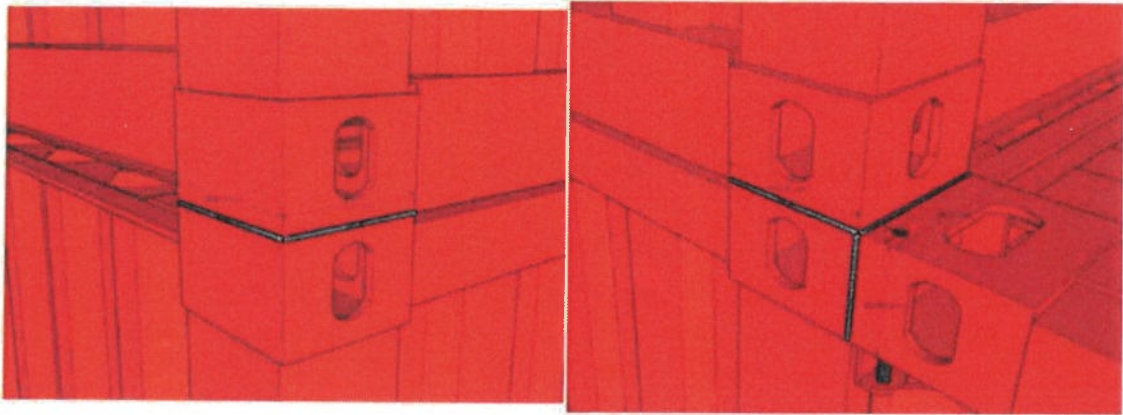

11

Attach brackets to concrete using Power Bolt System

Step 1

Installation Procedure
Using the proper diameter bit, drill a hole into the base material to a depth of at least 1/2" or one anchor diameter deeper than the embedment required. The tolerances of the drill bit used should meet the requirements of ANSI Standard B212.15.



Step 3

Drive the anchor through the fixture into the anchor hole until the bolt head is firmly seated against the fixture. Be sure the anchor is driven to the required embedment depth.



Step 2

Blow the hole clean of dust and other material. Do not expand the anchor or advance the bolt in the anchor assembly prior to installation.



Step 4

Tighten the anchor by turning the head 3 to 5 turns past finger tight or by applying the guide installation torque from the finger tight position.

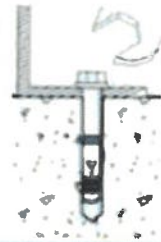

12

6"x6" HSS Column for Anchor Tie-offs

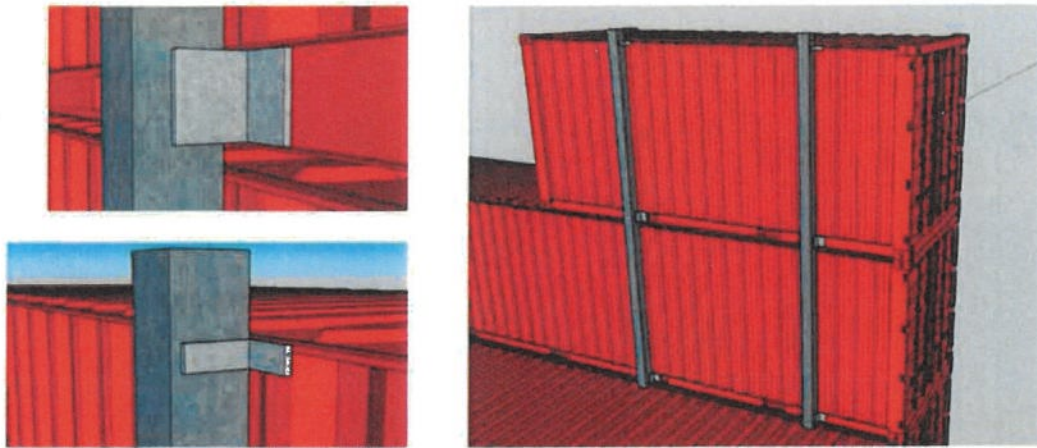

13

Anchor Tie-off Connection to HSS Column

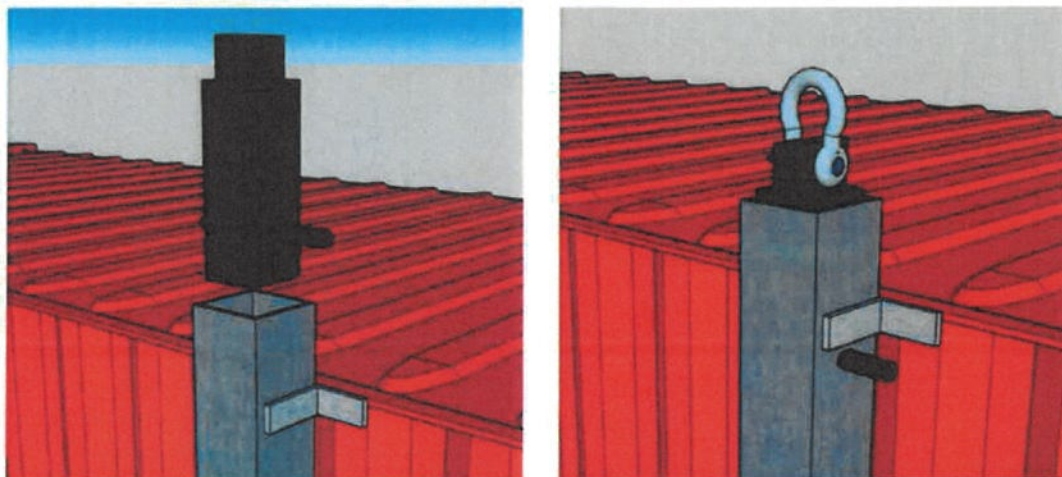

14

Metal Grating

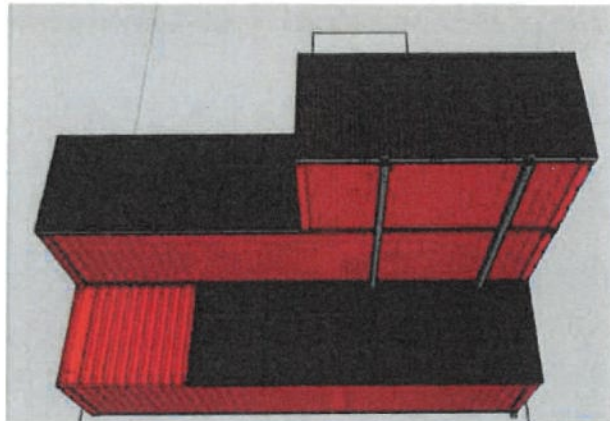
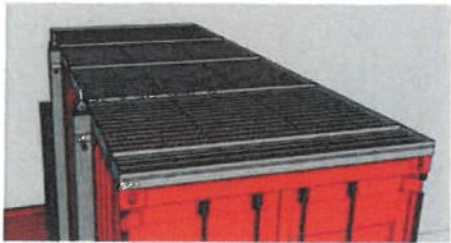

15

Cut 2'x2' Hole in Roof Over Burn Room

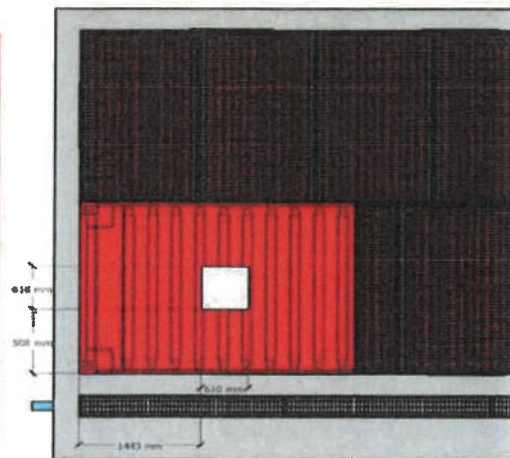
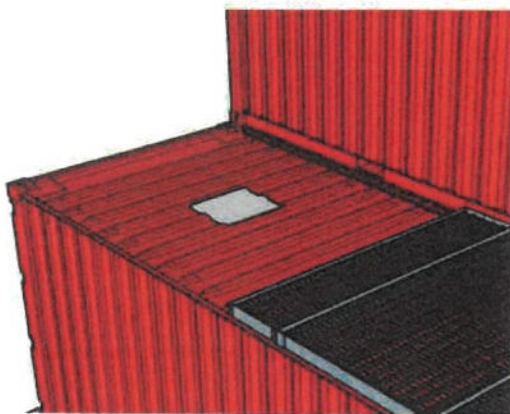

16

Ventilation Simulator - 2x8 Framework

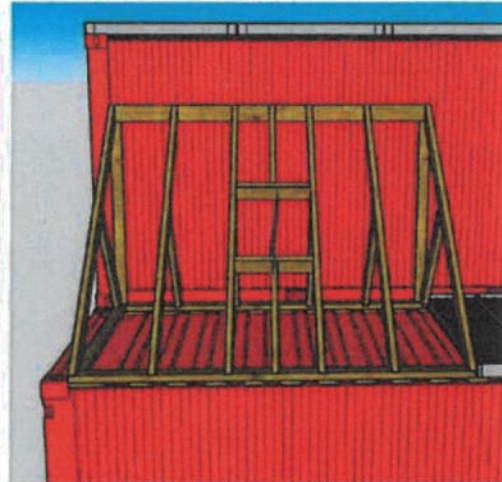
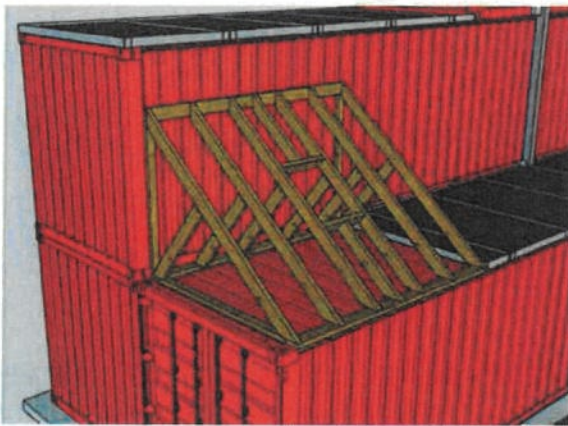

No Need to Frame out Hole.

17

Ventilation Simulator - Plywood

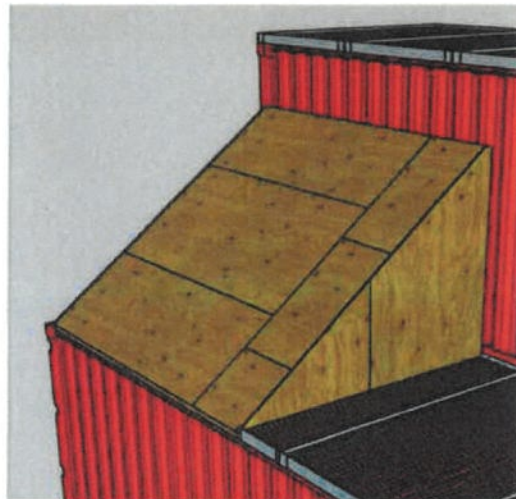
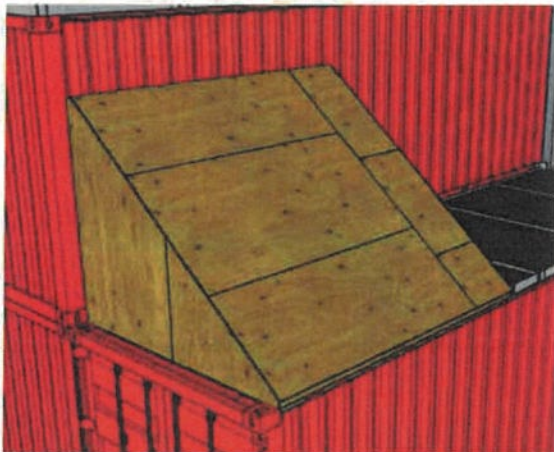

18

Ventilation Simulator - J Trim

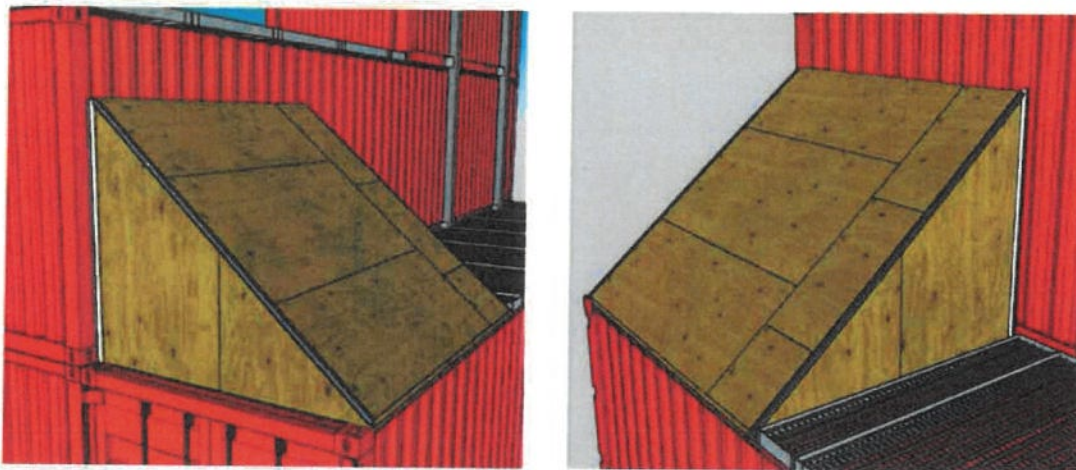

19

Ventilation Simulator - Red Sheet Metal Siding

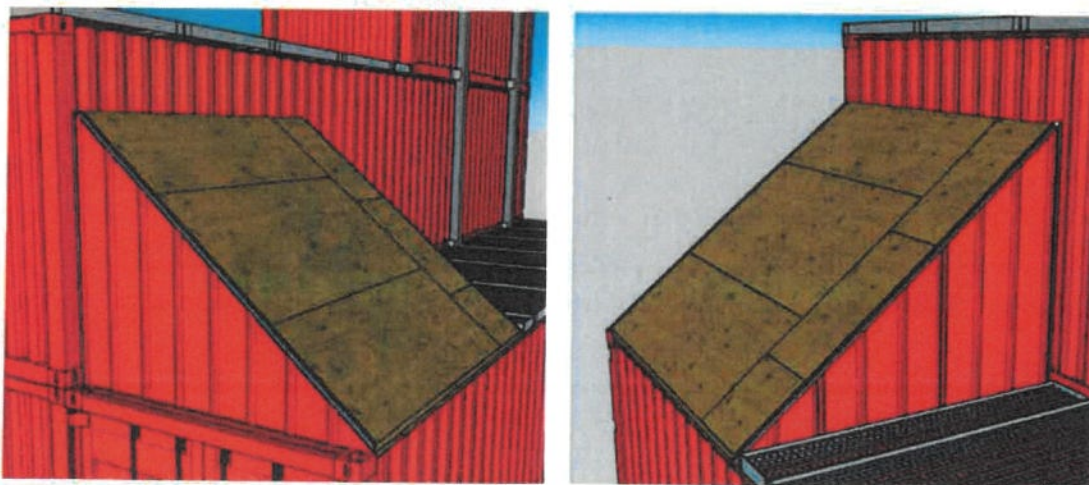

20

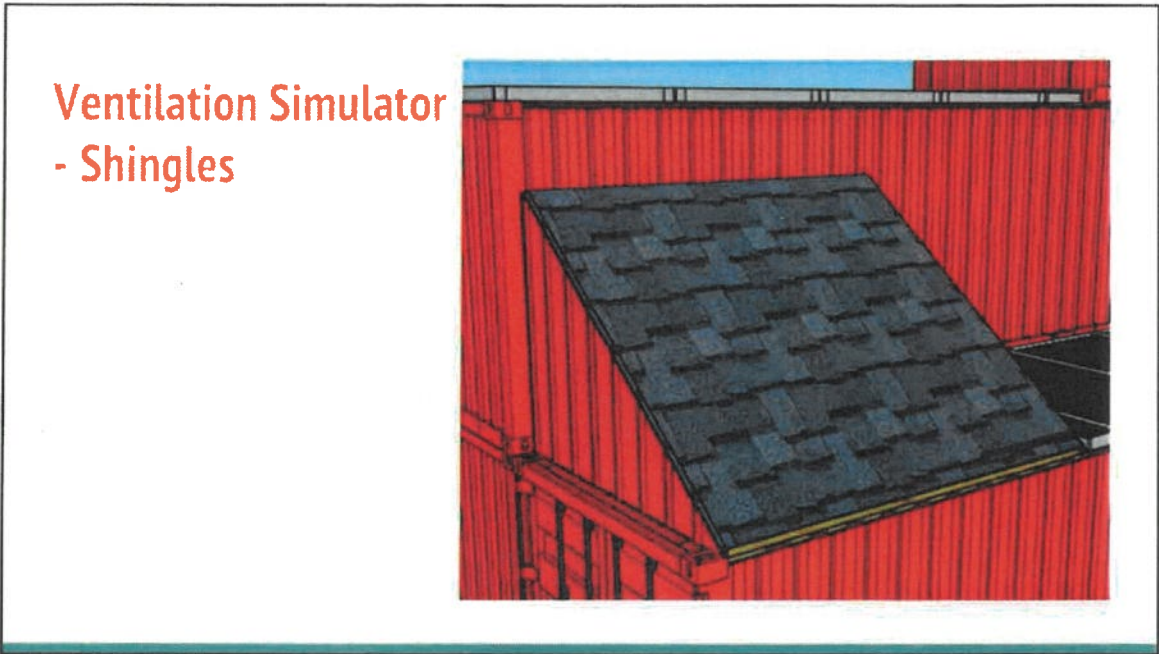

21

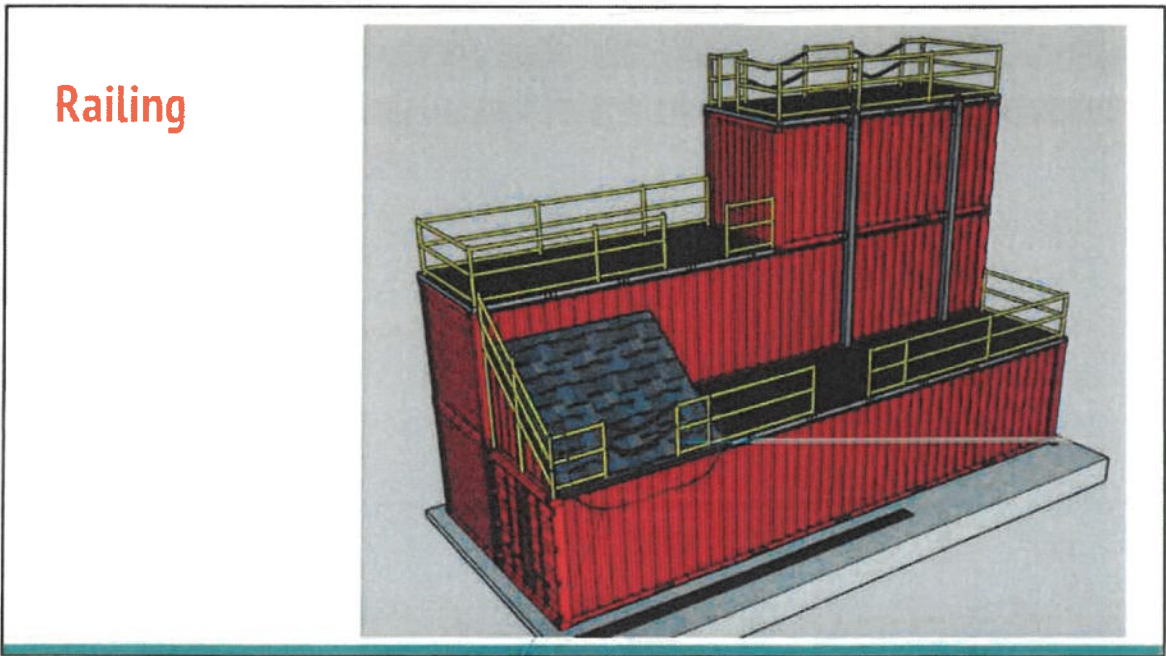

22

* No Rail At Boddom of
Ventilation Roof.

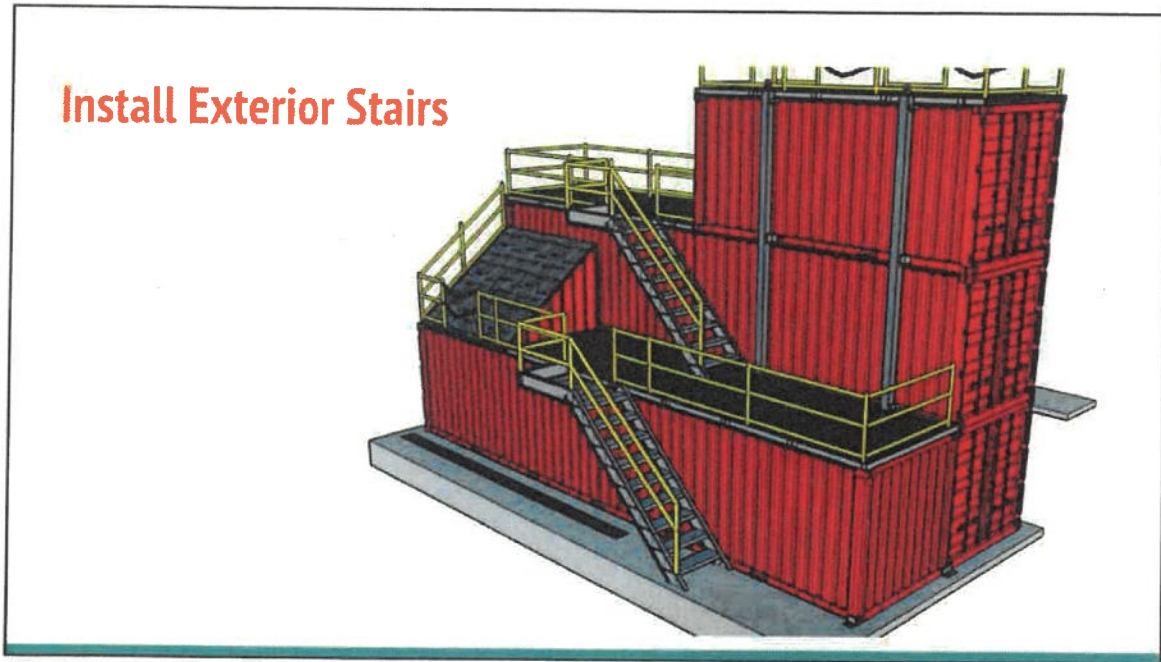

23

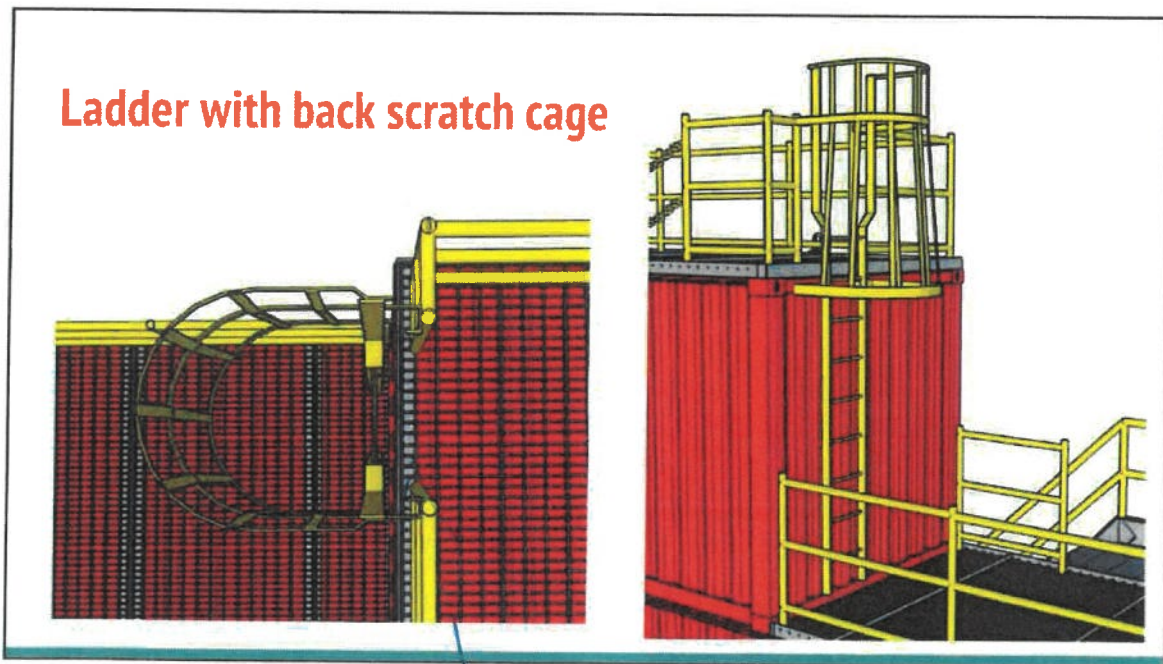

24

Safety gate

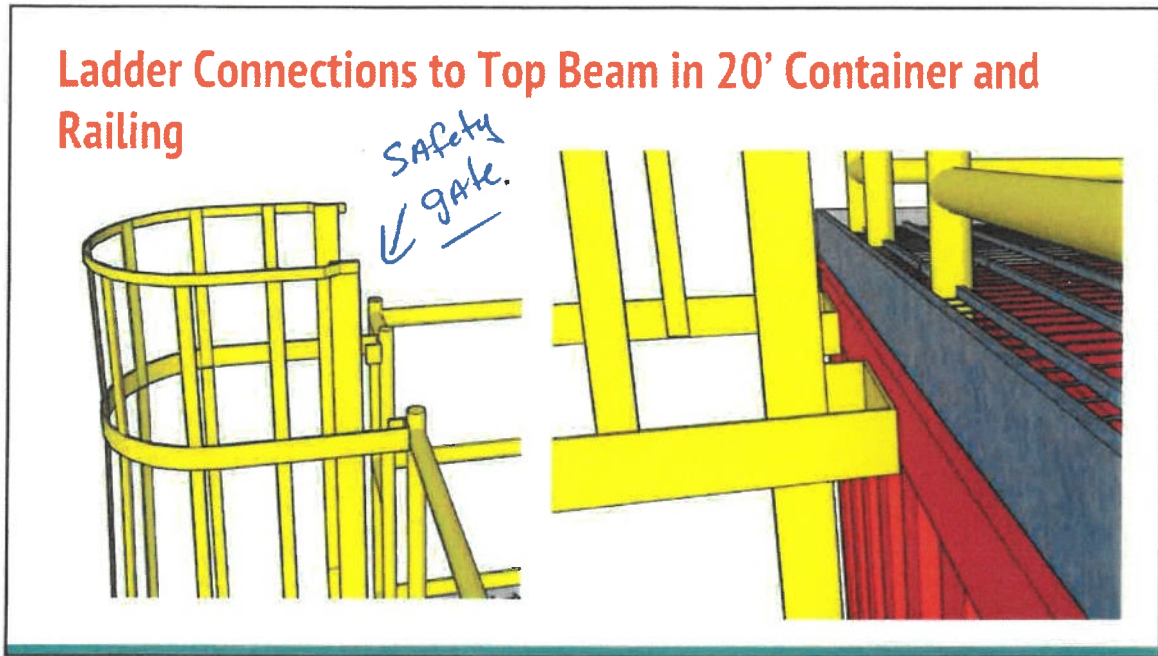

25

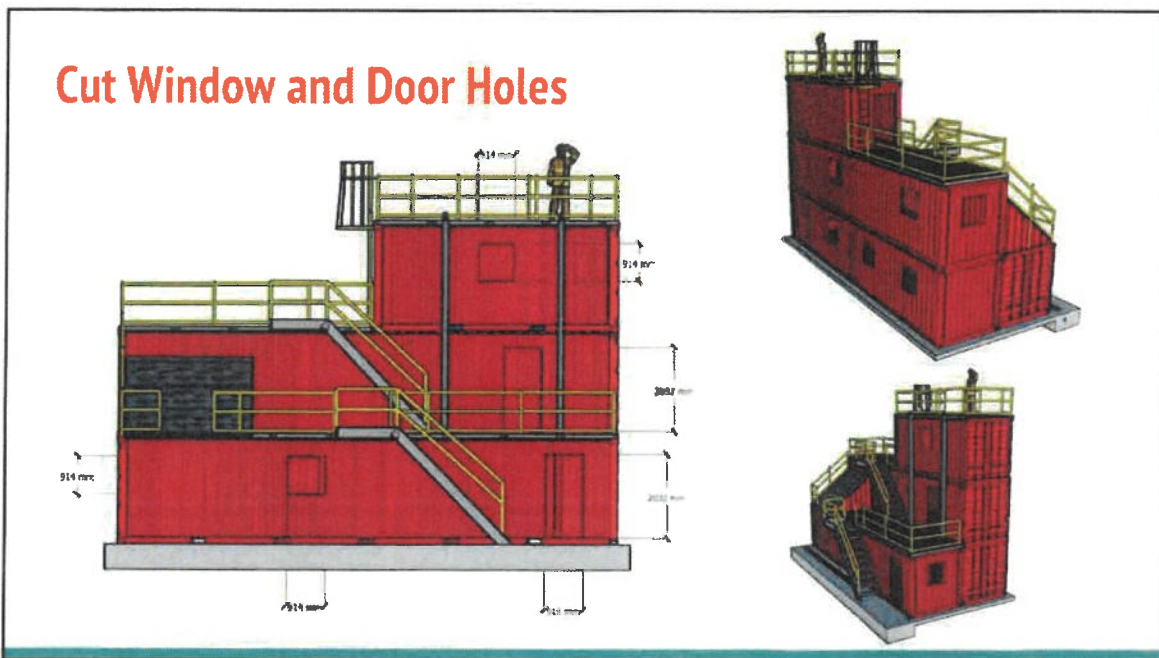

26

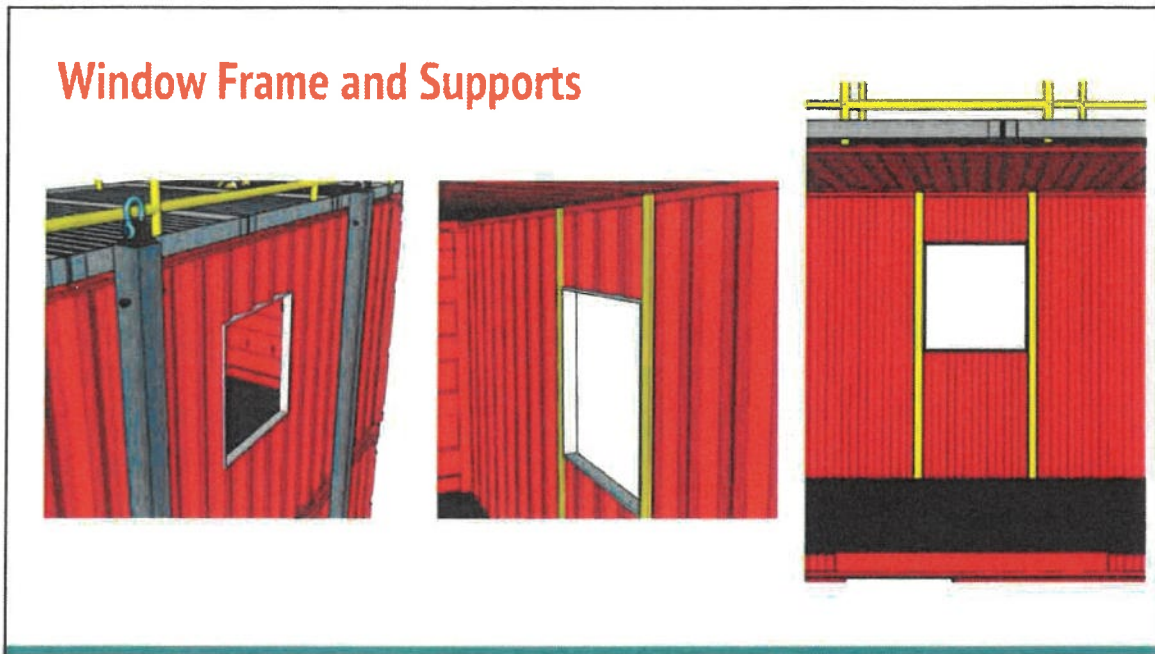

27

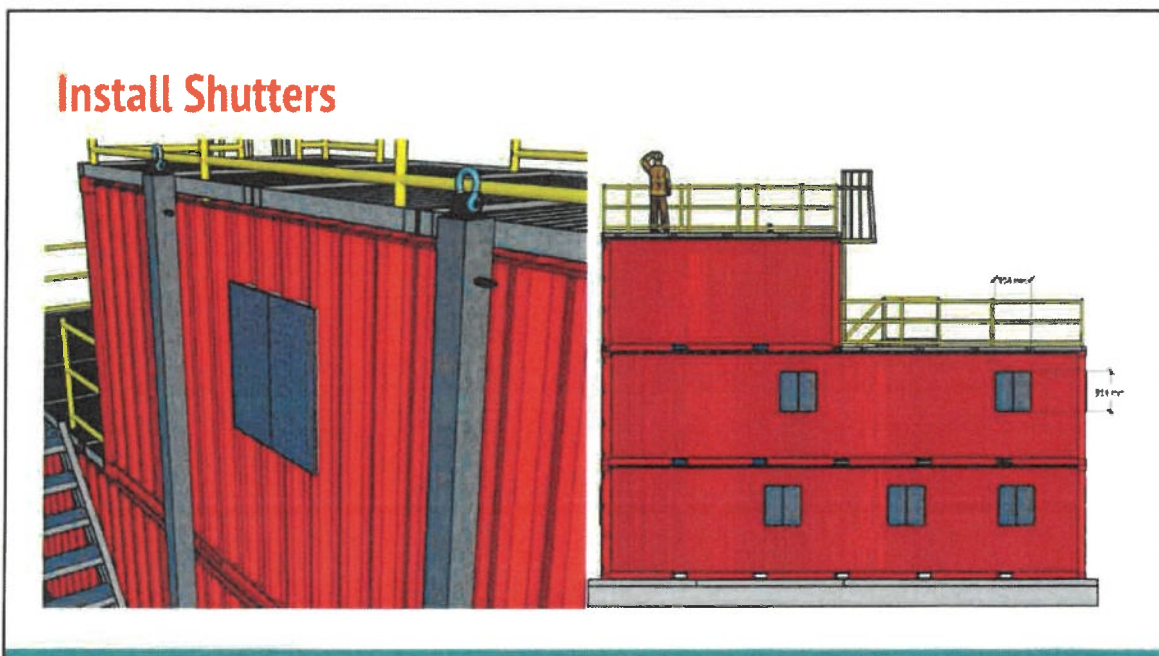

28

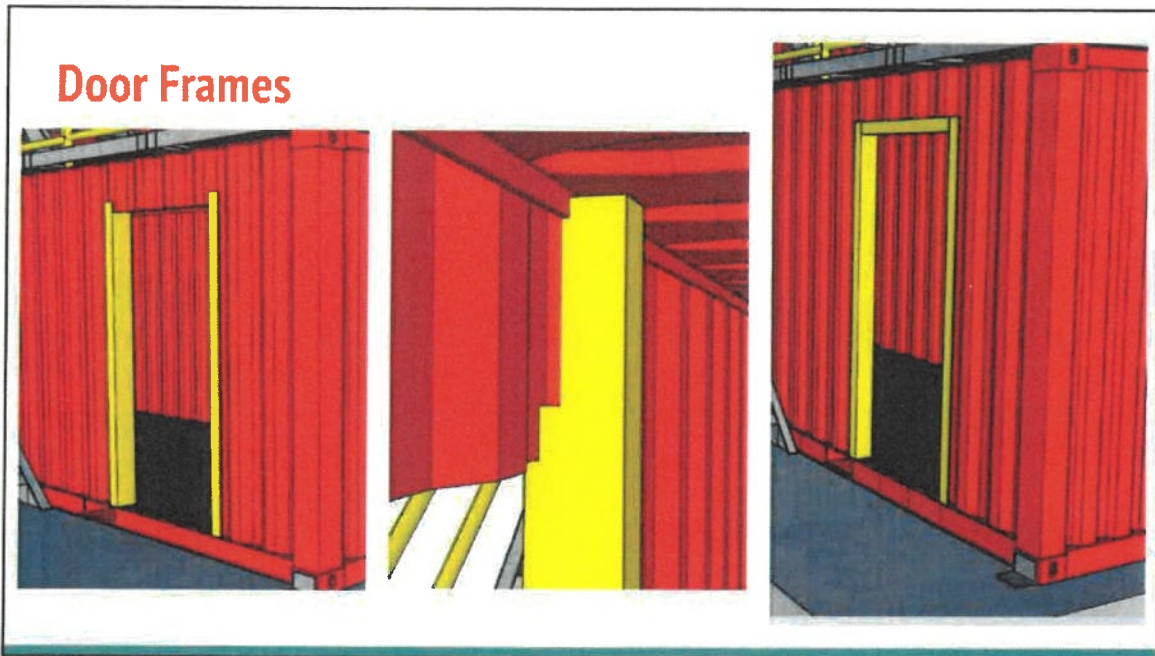

29

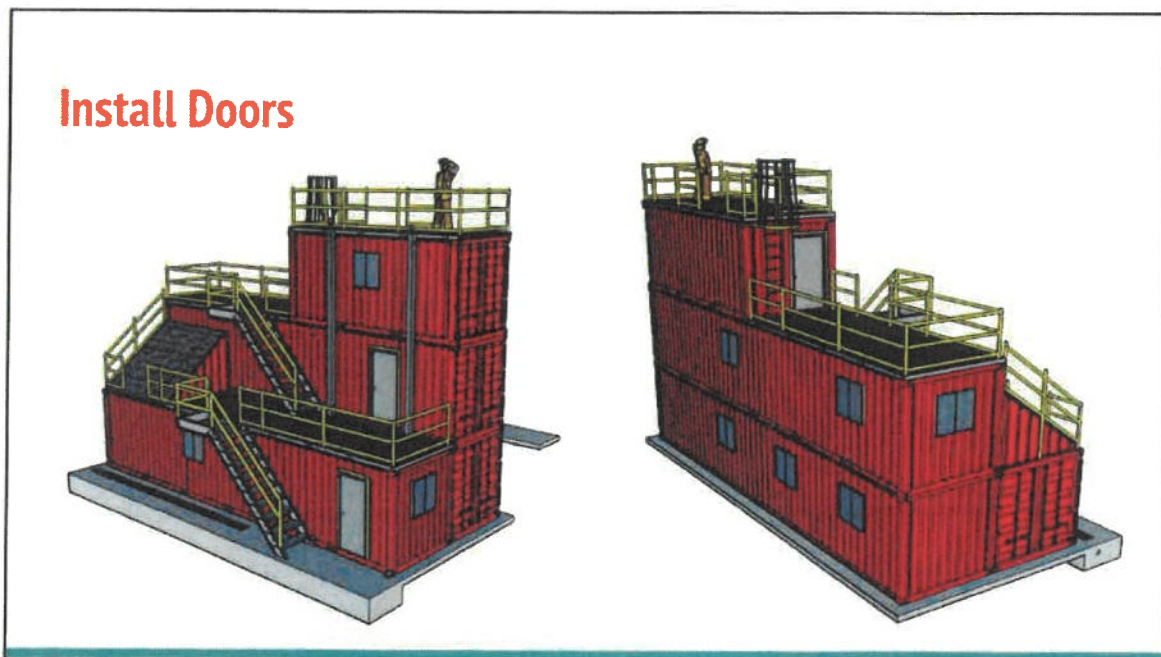

30

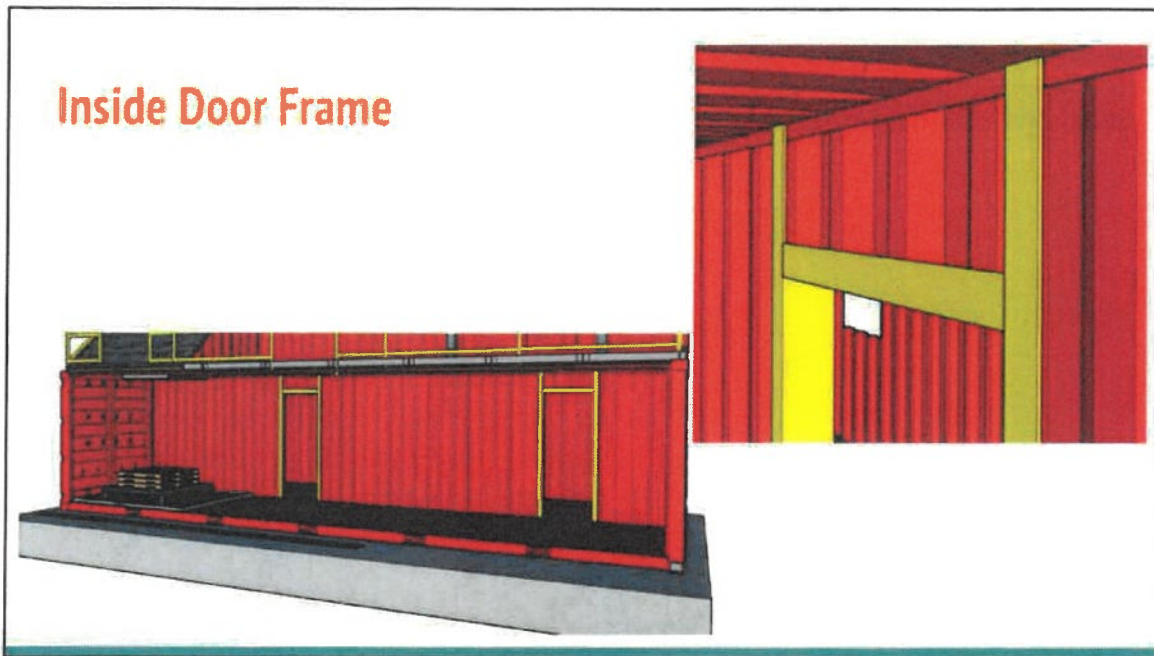

31

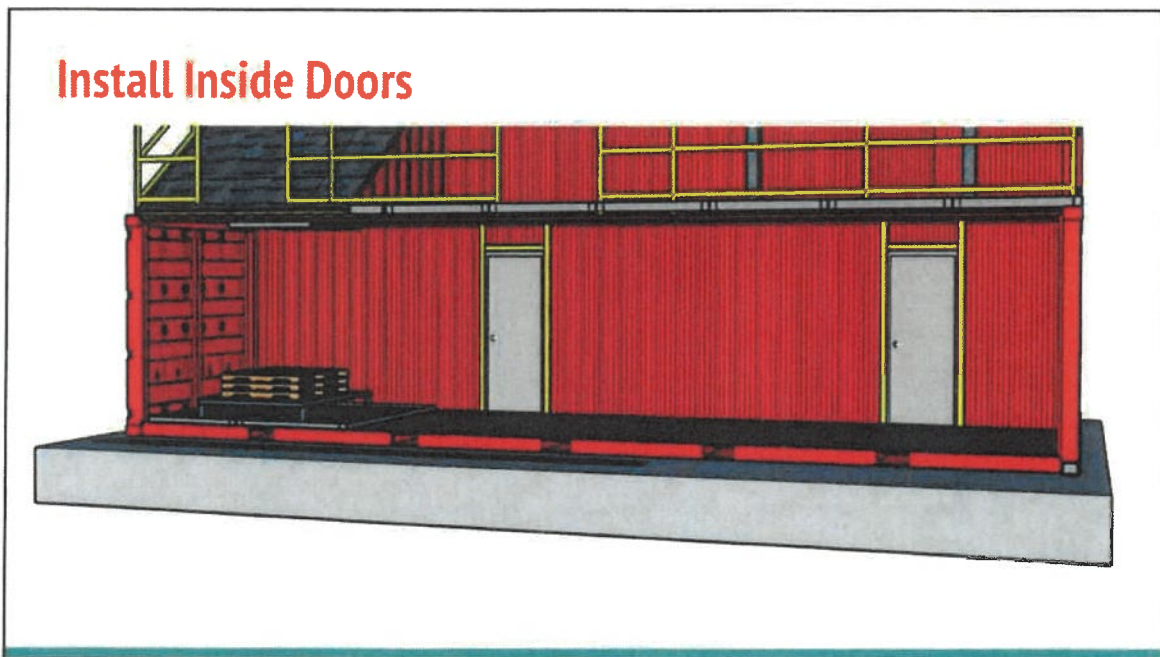

32

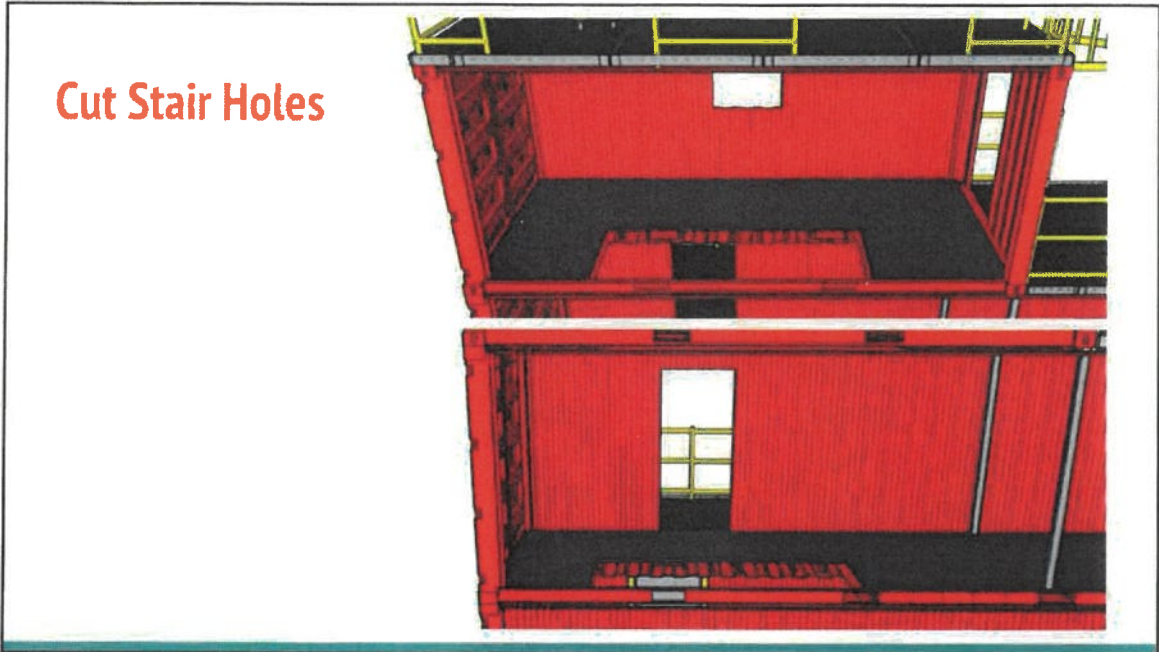

33



34

Cover Stair Cutout and Gap Between Floor and Roof Of Containers

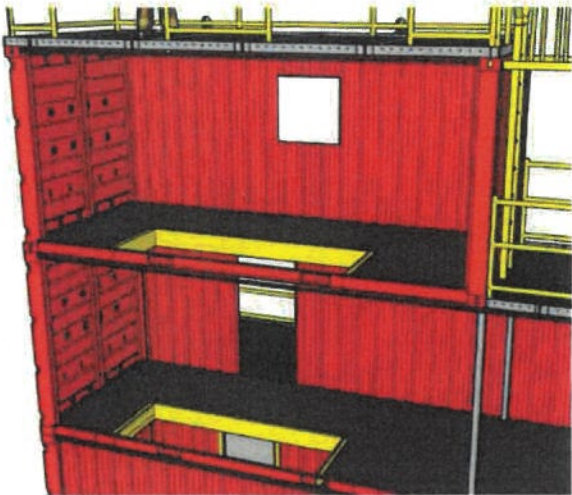

35

Install Stair Supports and Railing

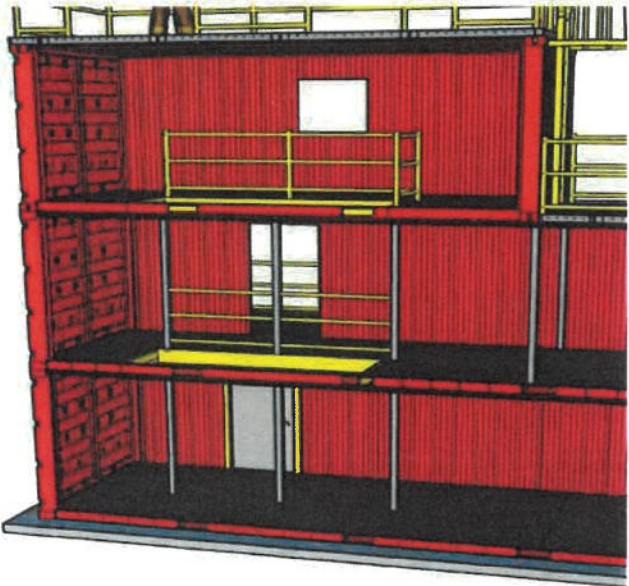

36

Install Interior Stairs

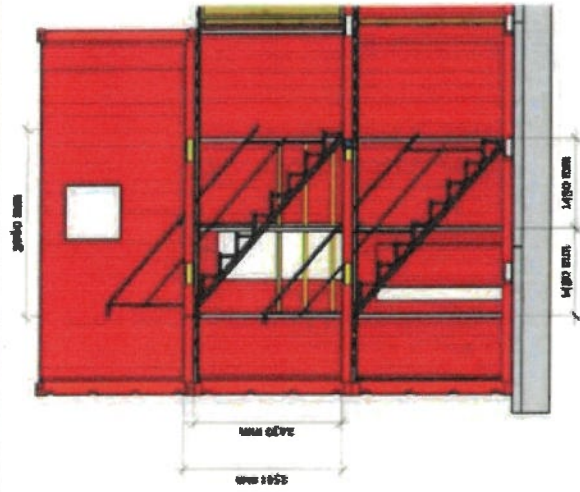
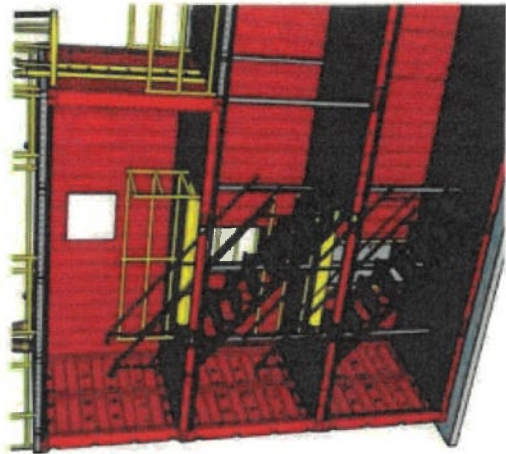

Folding Doors

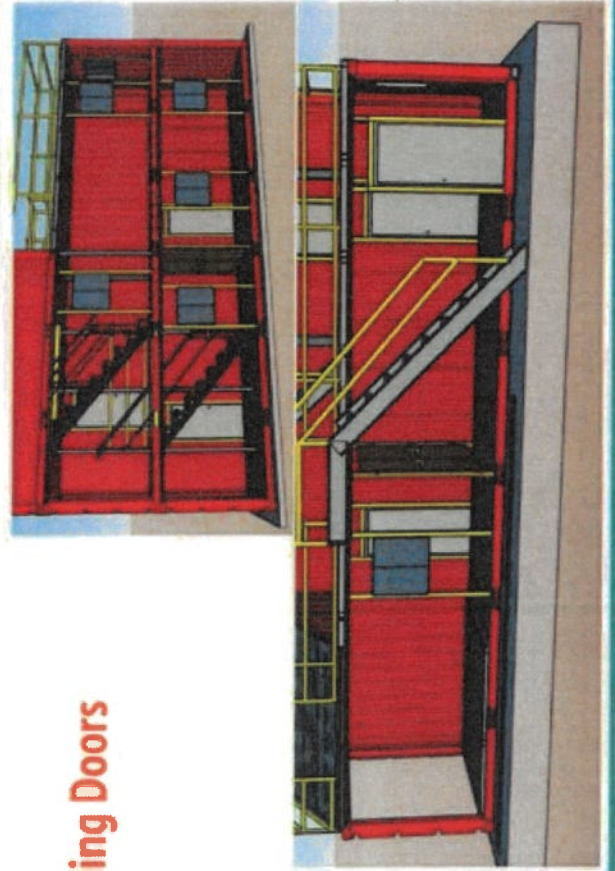

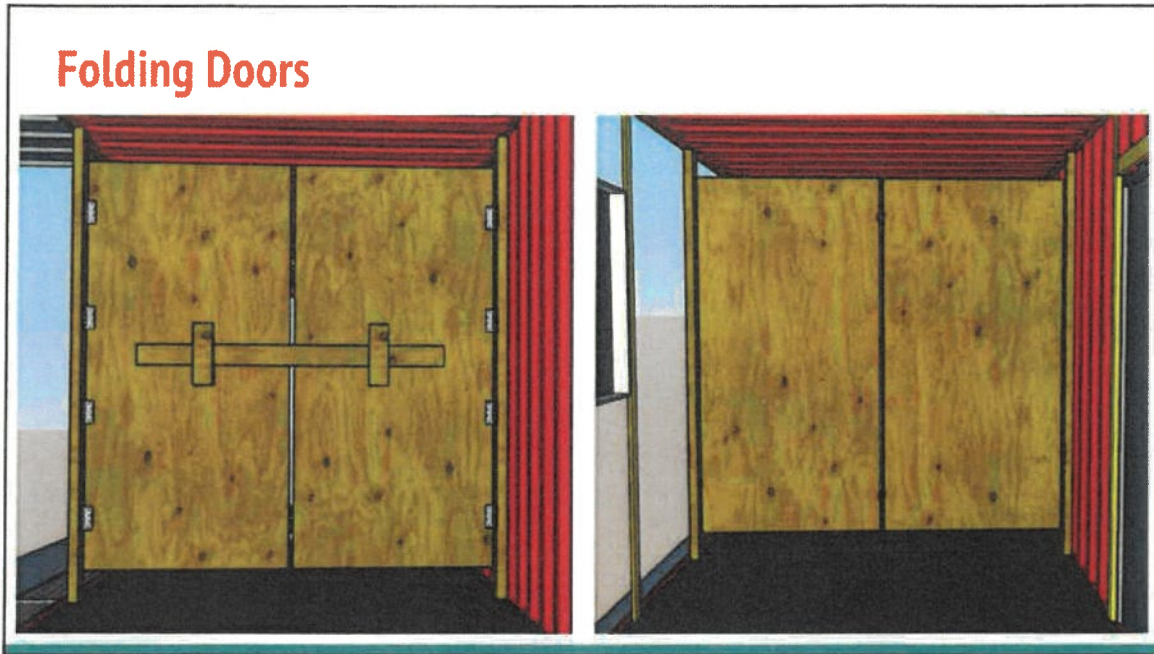

39

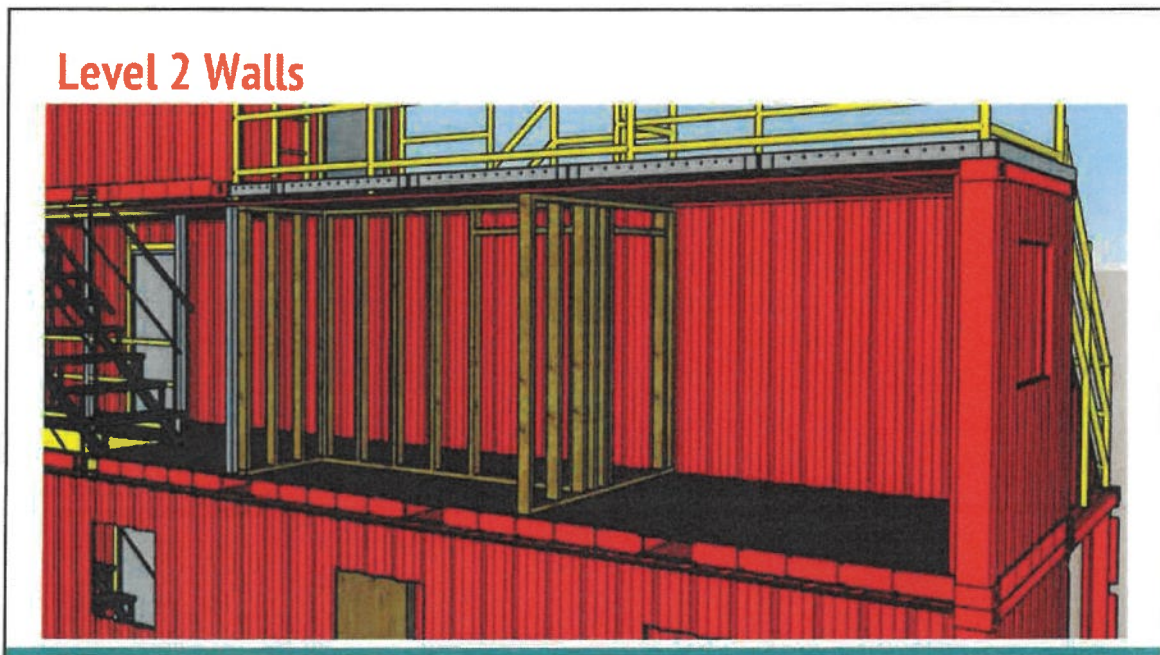

40

Level 2 Walls Plywood

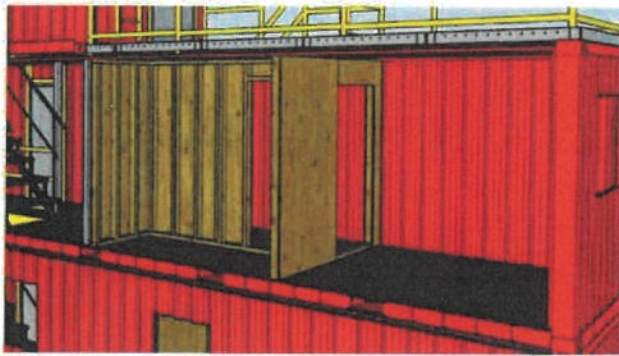

41

Install Inside Doors

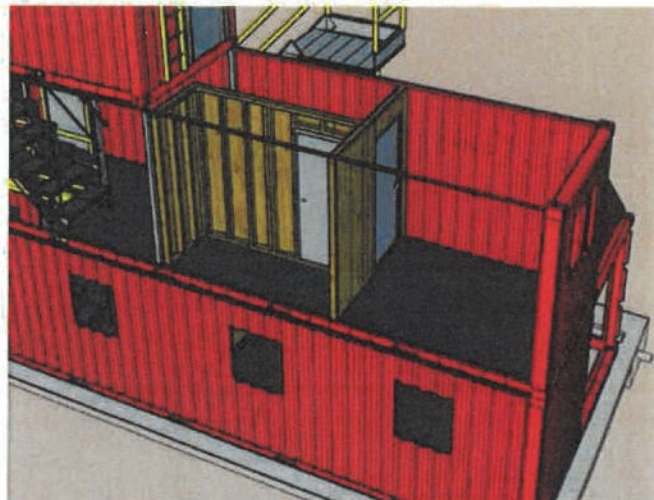
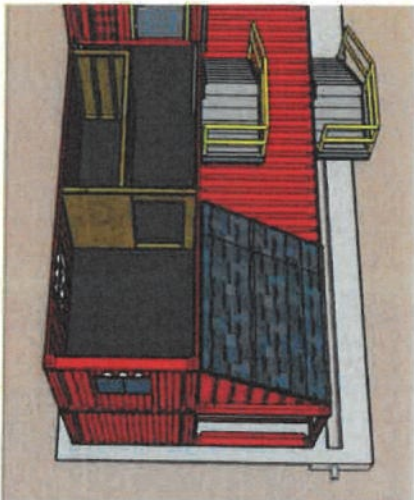

42

Remove 10' of Plywood Floor and Install Grating

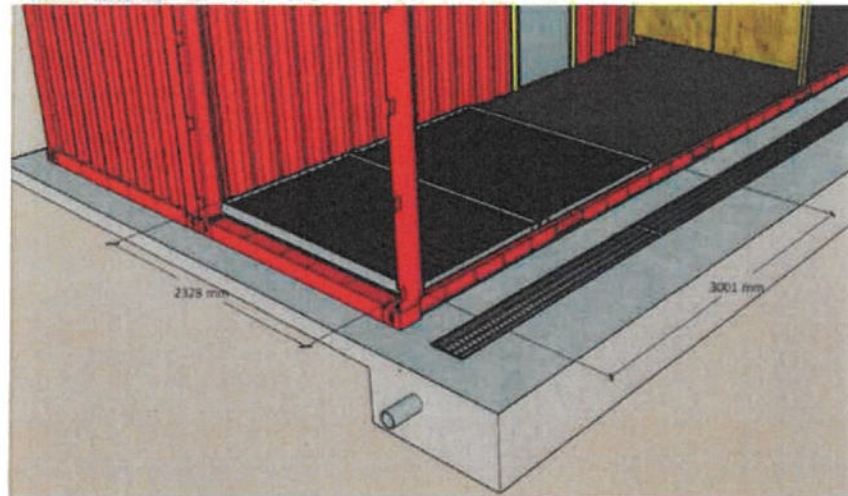

43

Burn Frame

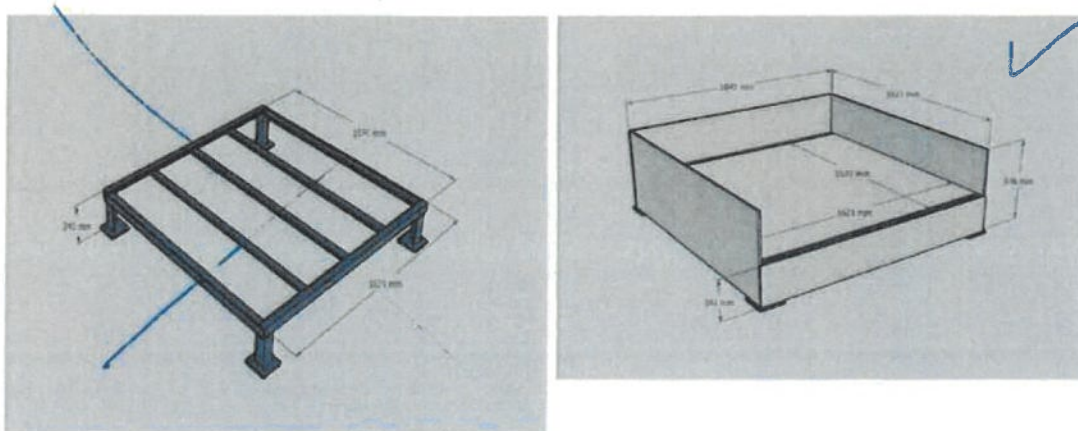

44

Drywall Breakthrough Holder

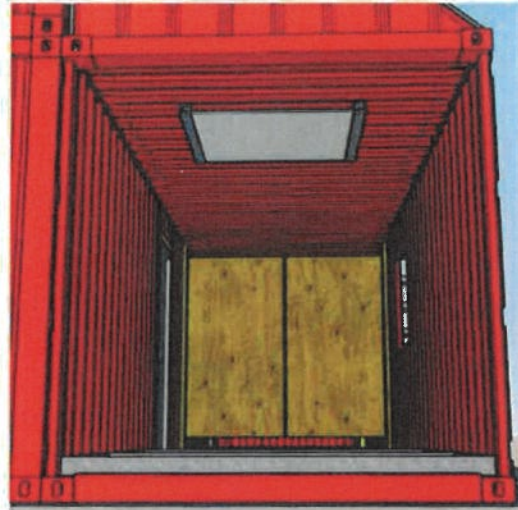

45

Sprinkler System



46

Sprinkler System

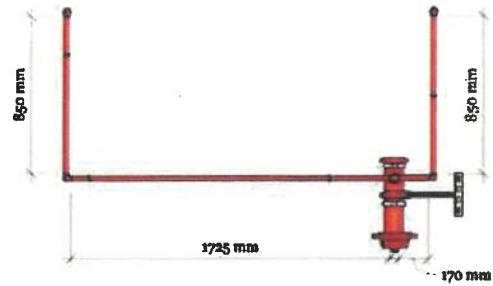
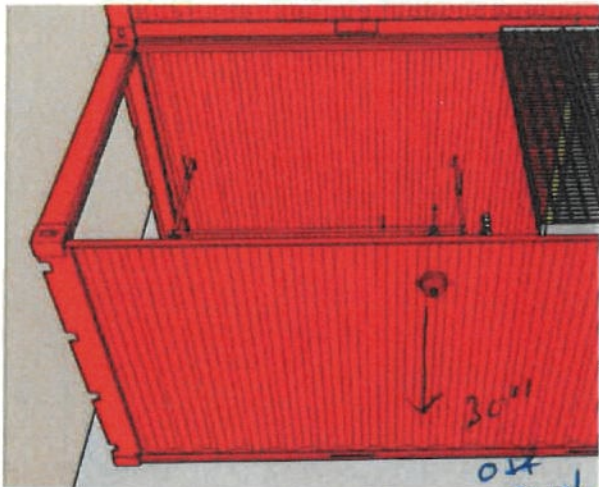

Top View

47

Place Burn Frame and Pallets in Burn Room

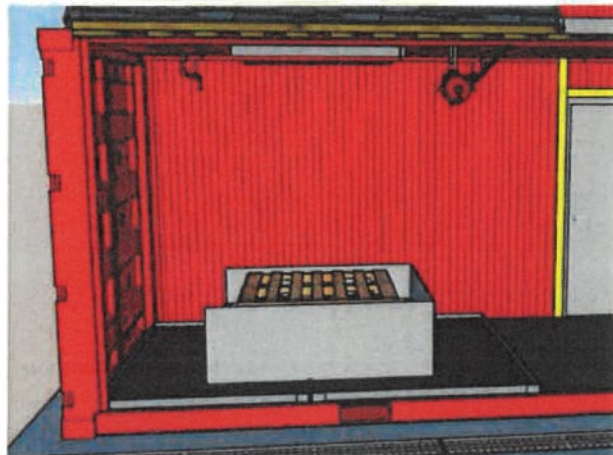
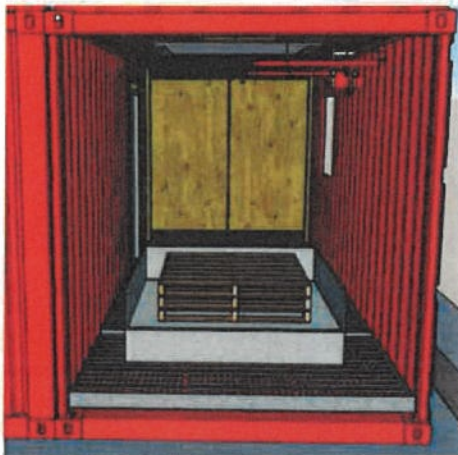

48

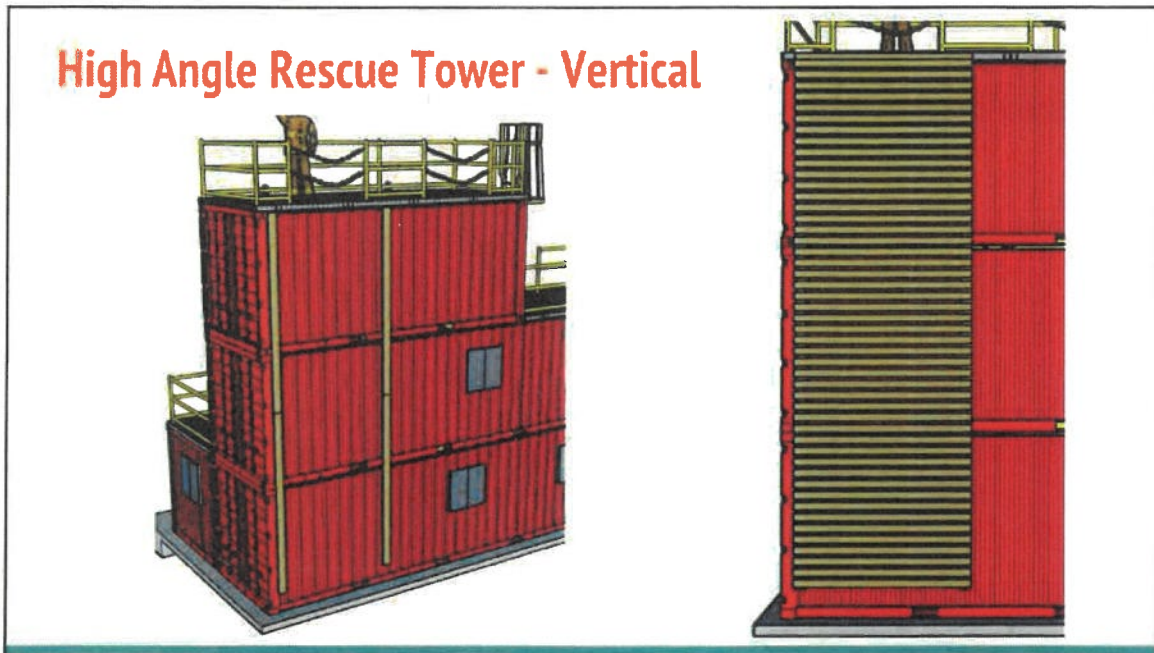

49

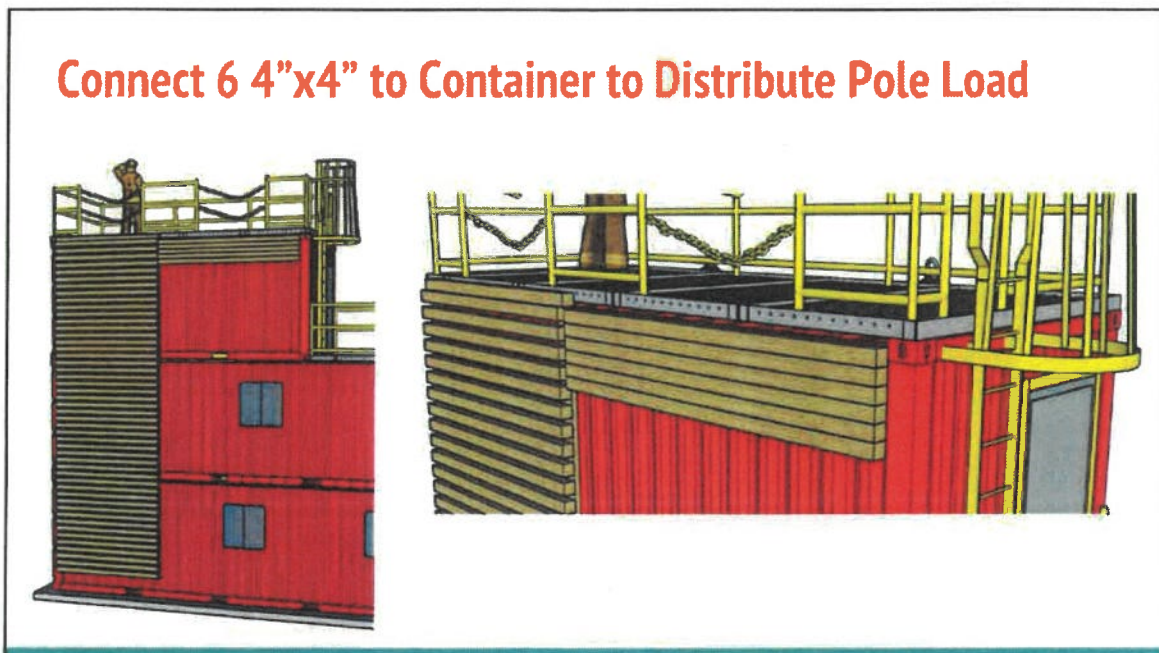

50

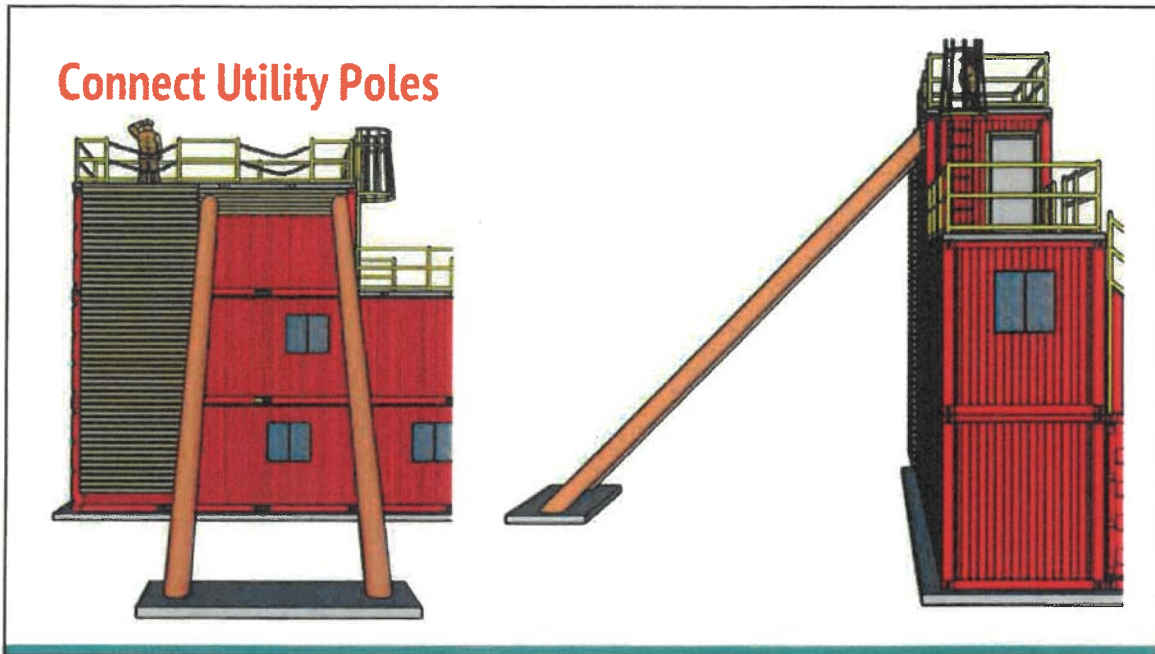

51

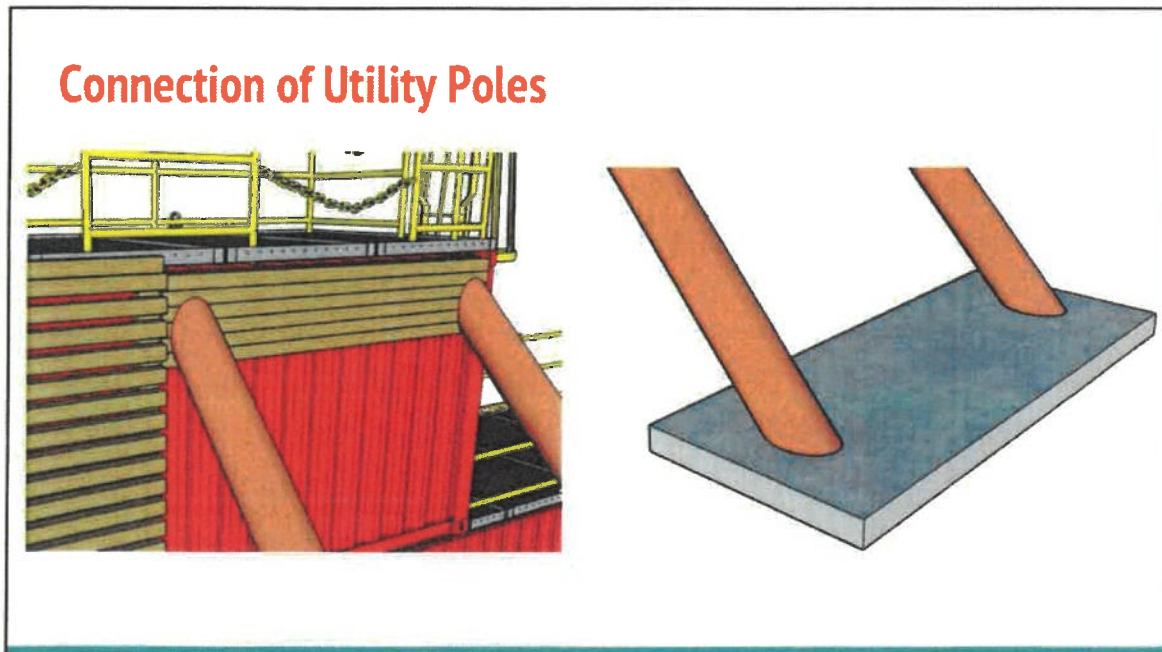

52

Install 4"x4" to 45deg Utility Poles

